

P/N 179024-001
Notice 1
July 29, 1981

OEM OPERATING AND SERVICE MANUAL
TM100-3, -3M, -4, AND -4M DISK DRIVES
96/100 TRACKS PER INCH

TO ALL HOLDERS OF P/N 179024-001:

1. Page 2-13, Sections 2.6 through 2.6.1.14, has been revised and supersedes the one in the manual.
2. Page 2-14, Sections 2.6.2 through 2.6.2.7, has been added to the manual.
3. Retain this notice and insert it before the table of contents.
4. Holders of P/N 179024-001 will verify that the page changes indicated herein have been entered. This notice will be retained as a check sheet. This issuance is a separate publication. Each notice is to be retained until the OEM operating and service manual is completely revised.

Preparing Group:
Product Support, Tandon Corporation

2.6.2 Track 00 Sensor Adjustment Procedure

- 2.6.2.1 Loosen the retaining screw on the base of the Track 00 bracket.
- 2.6.2.2 Retighten the retaining screw slightly to provide some friction on the bracket.
- 2.6.2.3 Rotate the Track 00 adjustment screw, located at the rear of the chassis, counterclockwise as far as it will go without forcing it.
- 2.6.2.4 Step the carriage back to Track 01 from the radial alignment track, taking care not to restore it back to Track 00.
- 2.6.2.5 Rotate the Track 00 adjustment screw clockwise, very slowly, until the signal at IC4B, Pin 9, is true (+5 volts) at Track 01 and false (0 volts) at Track 02.
- 2.6.2.6 Retighten the retaining screw.
- 2.6.2.7 Repeat Steps 2.6.1.5 through 2.6.1.14 to ensure that the correct setting has been attained.

2.6 TRACK 00 SENSOR CHECK AND ADJUSTMENT

The Track 00 sensor provides a signal that identifies Track 00 to the logic electronics. The logic electronics disable the step-in function when Track 00 is reached. In addition, a Track 00 signal is sent to the controller on Pin 26 of the interface.

2.6.1 Track 00 Sensor Check

2.6.1.1 Set up a dual-channel, wideband oscilloscope as follows:

Channel A, Test Point 1; Channel B, Test Point 2

Ground: Test Point 10

Read Differentially: A plus B, B inverted

Time Base: 20 msec Per Division

External Trigger: Test Point 7, Positive Edge

Vertical Display: 0.1 Volt Per Division

2.6.1.2 Apply power to the disk drive.

2.6.1.3 Insert a Cats Eye (CE) alignment diskette into the disk drive.

2.6.1.4 Close the front door.

2.6.1.5 Step the carriage to the radial alignment track.

2.6.1.6 Confirm the position by observing the CE pattern.

2.6.1.7 Set up the oscilloscope to monitor the TTL signal at IC4B, Pin 9, or at P11, Pin 2.

2.6.1.8 Step the carriage back to Track 01.

2.6.1.9 Ensure that the signal at Track 01 is logical true.

2.6.1.10 Step the carriage out to the radial alignment track.

2.6.1.11 Step the carriage back to Track 02.

2.6.1.12 Verify that the logic level at IC4B, Pin 9, is logical false.

2.6.1.13 If all of the above checks are satisfactory, no adjustment is required.

2.6.1.14 If one of the above checks is unsatisfactory, perform the Track 00 adjustment procedure.

**OEM
OPERATING AND SERVICE MANUAL
TM100-3, -3M, -4 AND -4M DISK DRIVES
96/100 TRACKS PER INCH**

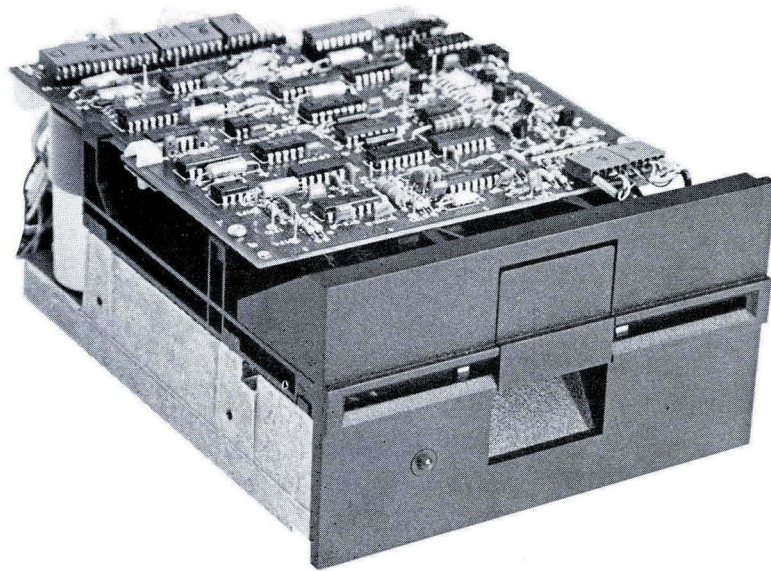

Tandon CORPORATION

20320 PRAIRIE STREET
CHATSWORTH, CA 91311

TELEPHONE (213) 993-6644
TWX 910 493 5965

COPYRIGHT 1981 TANDON CORPORATION

The information contained in this document is the property of Tandon Corporation. It may not be duplicated in full or part by any person without prior written approval. The material in this document is provided for informational purposes, and is subject to change by Tandon Corporation.

TABLE OF CONTENTS

<u>Section Number</u>	<u>Title of Section</u>	<u>Page Number</u>
SECTION I – INTRODUCTION TO THE TM100 FAMILY OF DISK DRIVES		
1.	Introduction	1-1
1.1	Purpose of The Disk Drive	1-1
1.2	Physical Description of The Disk Drive	1-1
1.3	Functional Description of The Disk Drive	1-1
1.4	Diskettes	1-2
1.5	Mechanical and Electrical Specifications	1-2
1.6	Interface Circuit Specifications	1-2
1.7	Uncrating The Disk Drive	1-2
1.8	Physical Checkout of The Disk Drive	1-4
1.9	Interface Connections	1-4
1.10	Chassis Ground	1-4
1.10.1	Isolated Ground	1-5
1.11	Mounting The Disk Drive	1-5
1.11.1	Dust Cover	1-6
1.11.2	Cooling System Requirements	1-6
1.12	Diskette Care, Handling, and Storage	1-6
1.13	Write Protect	1-6
1.14	Operation of The Disk Drive	1-6
1.15	Organization of The Disk Drive	1-7
1.16	Components of The Disk Drive	1-7
1.16.1	Index Pulse	1-7
1.16.2	Write Protect	1-7
1.16.3	Track 00 Sensor	1-7
1.16.4	Spindle Drive System	1-7
1.16.5	Positioner Control	1-8
1.16.6	Data Electronics	1-8
1.16.6.1	Data Recording	1-9
1.17	Interface Electronics	1-11
1.17.1	Interface Connector Pin Assignments, J1/P1	1-11
1.17.2	Power Connector Pin Assignments	1-11
1.18	Option Select	1-11
1.18.1	Input Line Terminations	1-11
1.18.2	Drive Select	1-14
1.19	Power Save Option	1-14
1.20	Agency Approvals	1-14
SECTION II – MAINTENANCE CHECKS AND ADJUSTMENTS		
2.	Introduction	2-1
2.1	Drive Motor Checks and Adjustments	2-1
2.1.1	Long-Term Drive Motor Speed Checks and Adjustment	2-1
2.1.2	Instantaneous Speed Variation Check	2-2
2.2	Cats Eye Alignment Check and Adjustment	2-3
2.2.1	CE Alignment Check	2-3
2.2.2	Head Adjustment	2-6

TABLE OF CONTENTS

<u>Section Number</u>	<u>Title of Section</u>	<u>Page Number</u>
SECTION II – MAINTENANCE CHECKS AND ADJUSTMENTS		
2.2.3	Track 00 Stop Adjustment	2-6
2.3	Index Four-Point Alignment Check and Adjustment	2-8
2.3.1	Index Four-Point Alignment Check	2-8
2.3.2	Index Adjustment	2-9
2.4	Compliance Check and Adjustment	2-10
2.4.1	Compliance Check	2-10
2.4.2	Compliance Adjustment	2-11
2.5	Write Protect Switch Adjustment Procedure	2-12
2.6	Track 00 Sensor Check and Adjustment	2-13
SECTION III – PRINTED CIRCUIT BOARD OPERATION		
3.	Introduction	3-1
3.1	Explanation of Symbols and Abbreviations	3-1
3.2	Physical Description of The Logic PCBA	3-1
3.3	Interface Electronics Specifications	3-3
3.3.1	Input Control Lines	3-4
3.3.1.1	Select Lines (NDS0-NDS3)	3-5
3.3.1.2	Drive Motor Enable (N MOTOR ON)	3-6
3.3.1.3	Direction and Step Lines (DIR) (N STEP)	3-7
3.3.1.4	Write Enable (N WRITE ENABLE)	3-10
3.3.1.5	Write Data (N WRITE DATA)	3-10
3.3.1.6	Side Select (N SIDE SELECT)	3-11
3.3.2	Outputs	3-14
3.3.2.1	Index (N INDEX/SECTOR)	3-14
3.3.2.2	Track 00 (N TRK 00)	3-15
3.3.2.3	Write Protect (N WRITE PROTECT)	3-15
3.3.2.4	Read Data (N READ DATA)	3-16
3.4	Physical Description of The Servo PCBA	3-19
3.4.1	Input Control Lines	3-19
SECTION IV – TROUBLESHOOTING GUIDE		
4.	Introduction	4-1
4.1	Not Ready and/or No Index	4-2
4.2	Will Not Seek or Restore	4-2
4.3	Will Not Write	4-2
4.4	Will Not Read	4-3
4.5	Front Panel LED Inoperative	4-3
4.6	No Track 00 Indication	4-3
SECTION V – REPLACEMENT PROCEDURES		
5.	Introduction	5-1
5.1	Drive Belt	5-2

TABLE OF CONTENTS

<u>Section Number</u>	<u>Title of Section</u>	<u>Page Number</u>
SECTION V – REPLACEMENT PROCEDURES		
5.2	Logic PCBA	5-3
5.3	Servo PCBA	5-4
5.4	Cone Lever Assembly	5-6
5.5	Cone Kit	5-10
5.6	Activity LED Assembly	5-12
5.7	Front Panel	5-14
5.8	Guide Rail	5-17
5.9	Index Assembly	5-19
5.10	Drive Motor Assembly	5-22
5.11	Track 00 Sensor Assembly	5-24
5.12	Write Protect Switch Assembly	5-27
5.13	Upper Arm Assembly (Single-Sided Drives Only)	5-30
5.14	Module Assembly	5-32
5.15	Spindle Asssembly	5-34
5.16	Latch Plate Assembly	5-37
APPENDIX I – PCB SCHEMATICS AND ASSEMBLY DRAWINGS		I-1
APPENDIX II – TIMING REQUIREMENTS		II-1
APPENDIX III – RECOMMENDED SPARE PARTS LIST		III-1

LIST OF ILLUSTRATIONS

FIGURES

<u>Figure Number</u>	<u>Title of Figure</u>	<u>Page Number</u>
SECTION I – INTRODUCTION TO THE TM100 FAMILY OF DISK DRIVES		
1-1	TM100 Disk Drive Mounting Configuration	1-5
1-2	TM100 Disk Drive Functional Block Diagram	1-8
1-3	FM Recording Magnetization Profiles	1-9
1-4	Write Operation Timing Diagram	1-10
1-5	Read Timing Diagram	1-11
1-6	Logic Printed Circuit Board Assembly	1-13
SECTION II – MAINTENANCE CHECKS AND ADJUSTMENTS		
2-1	Bottom View of The TM100 Disk Drive	2-2
2-2	Location of R4 Speed Control Pot	2-2
2-3	ISV Pulse Pattern	2-3
2-4	Hub Center Line and Track Locations	2-4
2-5	Cats Eye Pattern	2-5
2-6	Head Module Cap and Cam Screws	2-6
2-7	Track 00 Stop	2-7
2-8	Index-to-Data Pulse	2-8
2-9	Index Sensor's Retaining Screw and Adjustment	2-9
2-10	Upper Arm and Nuts	2-11
2-11	Write Protect Switch Adjustment	2-12
SECTION III – PRINTED CIRCUIT BOARD OPERATION		
3-1	Logic PCBA	3-1
3-2	Interface Configuration	3-3
3-3	Select Lines Schematic Diagram	3-5
3-4	Drive Motor Enable Schematic Diagram	3-6
3-5	Direction and Step Lines Schematic Diagram, Unipolar	3-8
3-6	Direction and Step Lines Schematic Diagram, Bipolar	3-9
3-7	Write Data Circuit Block Diagram	3-11
3-8	Write Data Schematic Diagram, Unipolar	3-12
3-9	Side Select Schematic Diagram	3-13
3-10	Index Schematic Diagram	3-14
3-11	Waveform at Test Point 7 (Soft Sector)	3-14
3-12	Track 00 Schematic Diagram	3-15
3-13	Write Protect Schematic Diagram	3-16
3-14	Read Data Schematic Diagram, Bipolar	3-17
3-15	Read Circuit Block Diagram	3-18
3-16	Servo PCBA	3-19
3-17	Servo Board Schematic Diagram	3-20

LIST OF ILLUSTRATIONS

FIGURES

<u>Figure Number</u>	<u>Title of Figure</u>	<u>Page Number</u>
SECTION V – REPLACEMENT PROCEDURES		
5-1	Drive Belt and Pulleys	5-2
5-2	Logic PCBA Connectors and Mounting Screws	5-3
5-3	Servo PCBA Connectors, Mounting Screws, and Spacers	5-4
5-4	Cone Lever Assembly Harnessing and Mounting	5-6
5-5	Cone Lever Assembly Harnessing, Mounting, and Stepper Motor Cables	5-7
5-6	Cone Lever Assembly Cable Harness	5-8
5-7	Cone Shaft and E-Ring	5-9
5-8	Cone's Component Parts	5-10
5-9	Activity LED Assembly Cable Harnessing	5-12
5-10	Activity LED Assembly Retaining Collar and LED Grommet	5-13
5-11	Front Panel Bushings	5-14
5-12	Activity LED Assembly Retaining Collar and Grommet	5-15
5-13	Front Panel Mounting Screws	5-15
5-14	Front Panel Bushings and Locating Tabs	5-17
5-15	Index Emitter Sensor Harnessing and Mounting	5-19
5-16	Index Detector Sensor Mounting Screw and Cable	5-20
5-17	Index Emitter and Index Detector Sensor Cables and Bundle	5-20
5-18	Drive Motor Assembly Harnessing and Mounting	5-22
5-19	Drive Motor Assembly Pulley	5-23
5-20	Track 00 Sensor Assembly Cable Harnessing	5-24
5-21	Track 00 Sensor Assembly E-Rings and Adjustment Screw	5-25
5-22	Track 00 Sensor Assembly and Mounting Screw	5-25
5-23	Write Protect Switch Assembly Arm and Adjustment Screw	5-27
5-24	Write Protect Switch Assembly Mounting Screw and Connector P8	5-28
5-25	Write Protect Switch Assembly Cable Harnessing	5-28
5-26	Nuts for Upper Arm and Spring Retainer	5-30
5-27	Upper Arm Assembly Parts	5-31
5-28	Felt Pad on Upper Arm	5-31
5-29	Module Assembly Parts	5-32
5-30	Spindle Assembly Mounting Screw, Washer, and Pulley	5-34
5-31	Spindle Assembly Retainer and Hex Head Screws	5-35
5-32	Latch Plate Assembly Mounting Screws and Latch Inhibitor	5-37

TABLES

<u>Table Number</u>	<u>Title of Table</u>	<u>Page Number</u>
SECTION I – INTRODUCTION TO THE TM100 FAMILY OF DISK DRIVES		
1-1	Mechanical and Electrical Specifications	1-3
1-2	Interface Connector Pin Assignments, J1/P1	1-12
1-3	Power Connector Pin Assignments	1-13

LIST OF ILLUSTRATIONS

TABLES

<u>Table Number</u>	<u>Title of Table</u>	<u>Page Number</u>
SECTION III – PRINTED CIRCUIT BOARD OPERATION		
3-1	Symbols and Abbreviations	3-2
3-2	Interface Connector Pin Assignments, J1/P1	3-4
3-3	Power Connector Pin Assignments	3-5
3-4	Stepper Logic Truth Table	3-7

SECTION I

INTRODUCTION TO THE TM100 FAMILY OF DISK DRIVES

1. INTRODUCTION

This section contains a description of the physical and functional specifications for the TM100 family of disk drives, 96 or 100 tracks per inch (TPI), manufactured by Tandon Corporation.

1.1 PURPOSE OF THE DISK DRIVE

The disk drive is a 5¹/₄" mini disk memory designed for random access data entry, storage, and retrieval applications. These applications typically are intelligent terminal controllers, microcomputers, word processing systems, data communications systems, error logging, microprogram loading, and point-of-sale terminals.

The disk drive is capable of recording and reading digital data, using FM, MFM, MMFM or GCR techniques.

1.2 PHYSICAL DESCRIPTION OF THE DISK DRIVE

The disk drive can be mounted in any vertical or horizontal plane. However, when mounted horizontally, the logic circuit board must be up.

The spindle is belt driven by a DC motor with an integral tachometer. The servo control circuit, suitably sized pulleys, and the tachometer control the speed of the spindle. The Read/Write head assembly is positioned by means of a stepper motor, split band, and a suitably sized pulley.

The Read/Write/Erase head assembly is a glass-bonded ferrite/ceramic structure. It has a life in excess of 20,000 hours.

For diskette loading, operator access is provided via a slot which is located at the front of the disk drive.

The electronic components of the disk drive are mounted on two Printed Circuit Board Assemblies (PCBA's), one of which (logic) is located above the chassis, the other of which (servo) is mounted at the rear of the unit. Power and interface signals are routed through connectors that plug directly into the logic PCBA.

1.3 FUNCTIONAL DESCRIPTION OF THE DISK DRIVE

The disk drive is fully self-contained. It requires no operator intervention during normal operation. The disk drive consists of a Spindle Drive system, a Head Positioning system, and a Read/Write/Erase system.

The TM100-3 and TM100-4 are 96 TPI disk drives. The TM100-3M and TM100-4M are 100 TPI disk drives. The TM100-3 and -3M are single-sided disk drives. The TM100-4 and -4M are double-sided disk drives. The only difference between the units is the number of heads in the disk drive.

When the front door is opened, access is provided for the insertion of a diskette. The diskette is accurately positioned by plastic guides and by the front latch inhibitor. The in/out location is ensured by the backstop.

Closing the front door activates the cone/clamp system, resulting in centering of the diskette and clamping of the diskette to the drive hub. The drive hub is driven at a constant speed of 300 rpm by a servo-controlled DC motor. The magnetic head is loaded into contact with the recording medium whenever the front door is closed.

The magnetic head is positioned over the desired track by means of a stepper motor/band assembly and its associated electronics. This positioner employs a one-step rotation to cause a one-track linear movement. When a write-protected diskette is inserted into the disk drive, the Write Protect sensor disables the write electronics of the disk drive, and a Write Protect output signal is applied to the interface.

When performing a write operation, a 0.1650 mm (0.0065 inch) data track is recorded. Then, this track is tunnel erased to 0.1524 mm (0.0060 inch).

Data recovery electronics include a low-level read amplifier, a differentiator, a zero crossing detector, and digitizing circuits.

No data decoding capability is provided in the basic disk drive.

The disk drive is also supplied with the following sensor systems:

1. A Track 00 sensor that senses when the Head/Carriage assembly is positioned at Track 00.
2. The Index sensor, which consists of a LED light source and phototransistor, is positioned such that a digital signal is generated when an index hole is detected. The Index sensor is a high resolution device that can distinguish holes placed close together, i.e., index sector holes in a hard-sectored diskette.
3. The Write Protect sensor disables the disk drive write electronics whenever a write-protected diskette is inserted (see Section 1.13).

1.4 DISKETTES

The disk drive uses a standard 133.4 mm (5.25 inch) diskette. Diskettes are available with a single index hole or with index and sector holes.

Single index hole diskettes are used when sector information is pre-recorded on the diskette. Multiple sector hole diskettes provide sector pulses by means of the Index sensor and electronics.

1.5 MECHANICAL AND ELECTRICAL SPECIFICATIONS

The mechanical and electrical specifications of the disk drive are listed in Table 1-1.

1.6 INTERFACE CIRCUIT SPECIFICATIONS

The interface circuits are designed so that a disconnected wire results in a false signal.

Levels:

True = +0.4 V (maximum)
False = +2.4 V (minimum)

1.7 UNCRATING THE DISK DRIVE

The disk drive is shipped in a protective container which, when bulk packaged, minimizes the possibility of damage during shipment. The following procedure is the recommended method for uncrating the disk drive.

1. Place the shipping container on a flat work surface.

TABLE 1-1
MECHANICAL AND ELECTRICAL SPECIFICATIONS

Media	Industry-Standard 133.4 mm (5.25 inch) diskette
Dimensions	
Height	85.85 mm (3.38 inches)
Width	149.1 mm (5.87 inches)
Length	203.2 mm (8.00 inches)
Weight	1.45 Kg (3.2 pounds)
Temperature (Exclusive of Media)	
Operating	16°C to 44°C (60°F to 112°F)
Nonoperating	-40°C to 71°C (-40°F to 160°F)
Relative Humidity (Exclusive of Media)	
Operating	20% to 80% Noncondensing
Nonoperating	5% to 95% Noncondensing
Head Settling Time	15 msec (Last Track Addressed)
Error Rates, Maximum	
Soft Read	1 per 10 ⁹ bits, Recoverable
Hard Read	1 per 10 ¹² bits, Nonrecoverable
Head Life	20,000 Hours, Normal Use
Media Life (For Reference Only)	3.6 x 10 ⁶ Passes Per Track
Disk Speed	300 rpm ± 1.5%, Long Term
Instantaneous Speed Variation	± 3%
Start/Stop Time	250/150 msec, Maximum
Transfer Rate	FM: 125,000 BPS MFM: 250,000 BPS
Bytes Per Disk, Unformatted, Double Density	
TM100-3	500,000
TM100-3M	480,000
TM100-4	1,000,000
TM100-4M	962,000
Recording Modes (Typical)	FM, MFM, MMFM, GCR
Power	
+ 12 VDC	± 0.6 VDC @ 900 mA (Average Maximum)
+ 5 VDC	± 0.25 VDC @ 600 mA (Average Maximum) with 100 mV Peak-to-Peak Ripple

2. Remove the upper half of the inner container.
3. Remove the disk drive from the lower half of the inner container.
4. Check the model number and top assembly description against the packing slip.
5. Examine the contents of the shipping container for possible damage.
6. Notify the carrier immediately if any damage is noted.

1.8 PHYSICAL CHECKOUT OF THE DISK DRIVE

Before applying power to the disk drive, the following inspection procedure should be performed:

1. Remove the plastic bag.
2. Remove the cable harness from the door latch of the disk drive.
3. Check that the front latch opens and closes. Note that when the door is opened, the head arm raises.
4. Ensure that the front panel is secure.
5. Manually rotate the drive hub. The drive hub should rotate freely.
6. Check that the PCBA's are secure.
7. Check that the connectors are firmly seated.
8. Check for debris or foreign material between the heads.
9. Notify the carrier immediately if any damage is noted.

1.9 INTERFACE CONNECTIONS

Signal connections for the disk drive are made via a user-supplied 34-pin, flat ribbon connector (3M Part Number 3463-0001 or equivalent). This connector mates directly with the PCBA connector at the rear of the disk drive. The DC power connector is a four-pin connector (Amp Mate-N-Lok Part Number 1-480424-0), which mates with the connector on the logic PCBA at the top rear of the disk drive.

The signal connector harness should be of the flat ribbon or twisted pair type, have a maximum length of ten (10) feet, and have a 22-to-24 gauge conductor compatible with the connector that is to be used.

Power connections should be made with 18-AWG cable (minimum). In addition, the PCBA-mounted, DC power connector is keyed.

1.10 CHASSIS GROUND

To ensure proper operation of the disk drive, the chassis should be connected to earth ground. A 3/16-inch male QC lug, located at the rear of the chassis, is provided to facilitate this connection.

1.10.1 Isolated Ground

The power return of the disk drive is connected to the drive chassis. If a particular application does not require this, the mounting screw near the middle of the servo PCB may be replaced with a nylon screw. This isolates the power return from the chassis ground. Tandon does not recommend isolating the ground.

1.11 MOUNTING THE DISK DRIVE

The disk drive has been designed such that it can be mounted in any plane, i.e.: upright, horizontal, or vertical. The only restriction is that the logic PCBA side of the chassis must be uppermost when the disk drive is mounted horizontally. Eight (8) 6-32 tapped holes are provided for mounting: two (2) on each side and four (4) on the bottom of the housing (see Figure 1-1).

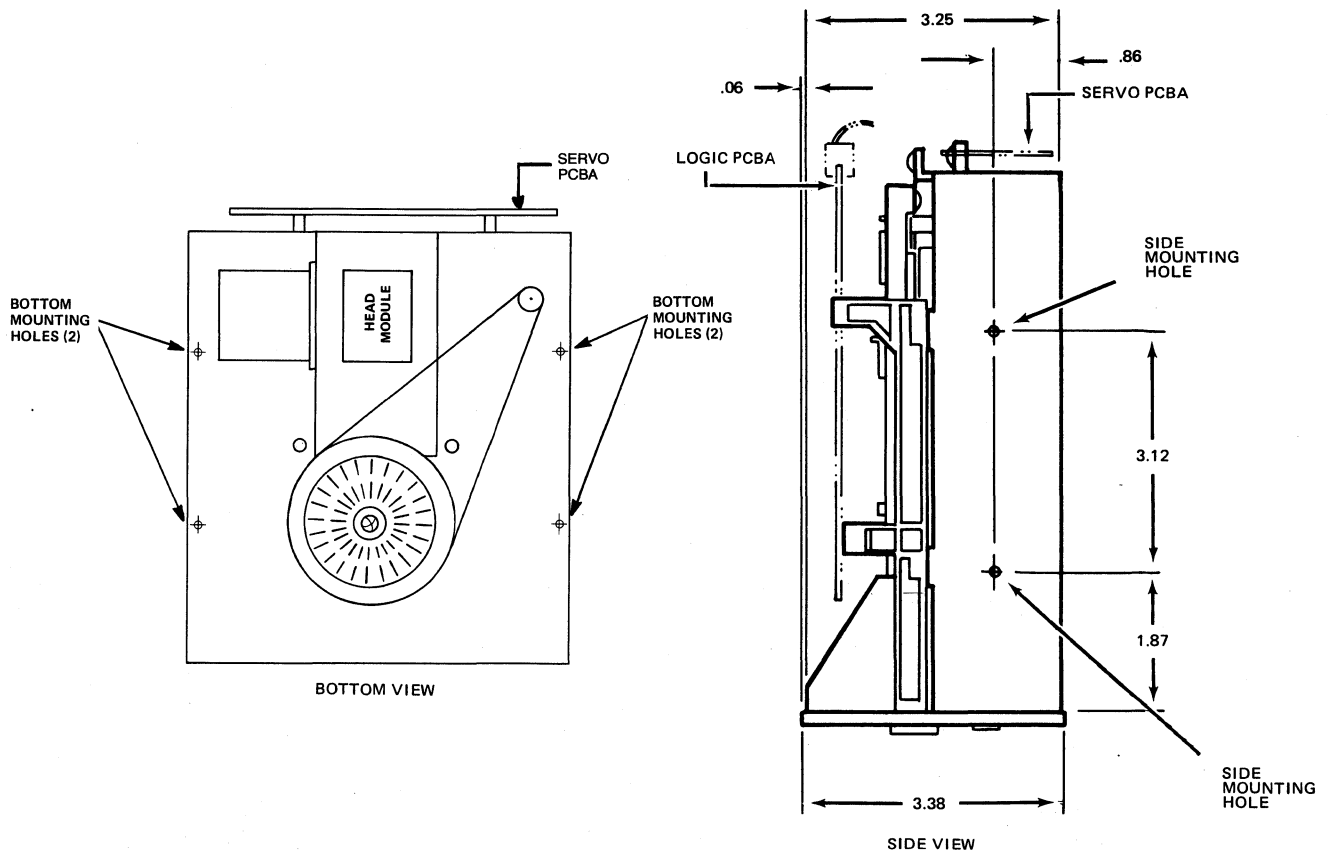

Figure 1-1
TM100 Disk Drive Mounting Configuration

NOTES

Improper mounting the the drive that stresses the chassis can cause misalignment and create an interchange problem. When mounting the drive from the bottom, ensure that the mounting surface is sufficiently rigid and proper torque is applied to prevent stressing the chassis.

After installation, it is recommended that the alignment be rechecked to ensure that the mounting technique has not caused drive misalignment.

NOTES

Any mounting scheme in which the disk drive is part of the structural integrity of the enclosure may cause equipment operating problems and should be avoided.

Mounting schemes should allow for adjustable brackets or incorporate resilient members to accommodate tolerances.

1.11.1 Dust Cover

The design of an enclosure should incorporate a means to prevent contamination from loose items — e.g., dust, lint, paper chad — since the disk drive does not have a dust cover.

1.11.2 Cooling System Requirements

Heat dissipation from a single disk drive is normally 15 watts (51 Btu/Hr.) under high line conditions. When the disk drive is mounted so that the components have access to the free flow of air, normal convection cooling allows operation over the specified temperature range.

When the disk drive is mounted in a confined environment, air flow must be provided to maintain specified air temperatures in the vicinity of the motors, the PCBA's, and the diskette.

1.12 DISKETTE CARE, HANDLING, AND STORAGE

It is important that the diskette be cared for, handled, and stored properly so that the integrity of the recorded data is maintained. A damaged or contaminated diskette can impair or prevent recovery of data, and can result in damage to the Read/Write heads of the disk drive.

The following list contains information on how the diskette can optimally be cared for, handled, and stored.

1. Keep the diskette away from magnetic fields.
2. Do not touch the precision surface of the diskette with fingers.
3. Insert the diskette carefully into the disk drive until the backstop is encountered.
4. Do not bend or fold the diskette.
5. Put the diskette into its jacket when it is not in use.
6. Store the diskette at temperatures from 13°C to 49°C (55°F to 120°F).

1.13 WRITE PROTECT

The disk drive is equipped with a Write Protect Switch Assembly. This sensor operates in conjunction with a diskette that has a slot cut in the protective jacket.

When the slot is covered with a self-adhesive tab, the diskette is write protected. The slot must be uncovered to write on the diskette.

1.14 OPERATION OF THE DISK DRIVE

The disk drive consists of the mechanical and electrical components necessary to record and to read digital data on a diskette. User-provided DC power at +12 V and +5 V is required for operation of the disk drive.

1.15 ORGANIZATION OF THE DISK DRIVE

All electrical subassemblies in the disk drive are constructed with leads that terminate in 4- to 5-pin connectors, enabling the individual assemblies to be removed.

The magnetic heads are connected to the PCBA via cables that terminate in 5-pin female connectors and their associated male sockets, which are located in close proximity to the Read/Write data electronics.

Interface signals and power are provided via connectors at the rear of the disk drive.

1.16 COMPONENTS OF THE DISK DRIVE

The disk drive consists of seven (7) functional groups:

1. Index Pulse Shaper
2. Write Protect Sensor
3. Track 00 Sensor
4. Spindle Drive Control
5. Carriage Position Control
6. Write/Erase Control
7. Read Amplifier and Digitizer

Figure 1-2 is a functional block diagram of the disk drive.

1.16.1 Index Pulse

An index pulse is provided to the user system via the Index Pulse interface line. The index circuitry consists of an Index LED, an Index Photo Transistor, and a Pulse Shaping Network. As the index hole in the disk passes the Index LED/Photo Transistor combination, light from the LED strikes the Index Photo Transistor, causing it to conduct. The signal from the Index Photo Transistor is passed to the Pulse Shaping Network, which produces a pulse for each hole detected. This pulse is presented to the user on the Index Pulse Interface line.

1.16.2 Write Protect

A Write Protect signal is provided to the user's system via the Write Protect interface line. The Write Protect circuitry consists of a Write Protect sensor and circuitry that routes the signal that is produced.

When a write protected diskette is inserted in the disk drive, the sensor is activated and the logic disables the write electronics and supplies the status signal to the interface.

1.16.3 Track 00 Sensor

The level on the Track 00 interface line is a function of the position of the magnetic head assembly. When the head is positioned at Track 00 and the stepper motor is at the home position, a true (low) level signal is generated at the interface.

1.16.4 Spindle Drive System

The Spindle Drive system consists of a spindle assembly driven through a drive belt by a DC motor/tachometer combination.

The servo electronics required for speed control are associated with the spindle drive motor.

The control circuitry also includes a current limiter and interface control line. When the Drive Motor Enable interface line is true, the drive motor is allowed to come up to speed. When the current through the drive motor exceeds 1.3 amperes, the current limit circuitry disables the motor drive.

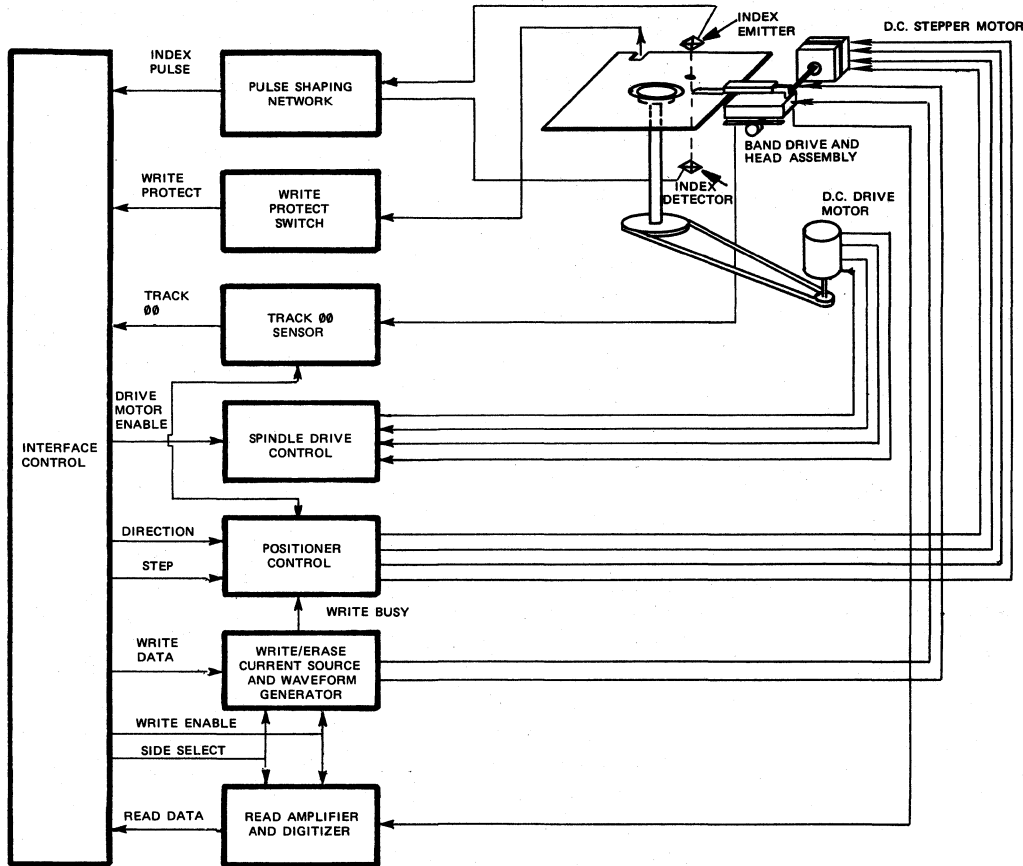

Figure 1-2
TM100 Disk Drive Functional Block Diagram

1.16.5 Positioner Control

The Head Positioning system utilizes a four-phase stepper motor drive, which changes one phase for each track advancement of the Read/Write carriage. In addition to the logic necessary for motion control, a gate is provided which inhibits positioner motion during a write operation.

1.16.6 Data Electronics

Information can be recorded on the diskette by using a double-frequency code. Figure 1-3 illustrates the magnetization profiles in each bit cell for the number sequence shown for FM recording.

The erase gaps provide a guard band on either side of the recorded track. This provides flexibility in track positioning.

All signals required to control the data electronics are provided by the user system and are shown in the TM100 disk drive functional block diagram (see Figure 1-2). These control signals are:

1. Select
2. Write Enable

3. Write Data
4. Side Select

The Read Data composite signal is sent to the user system via the interface.

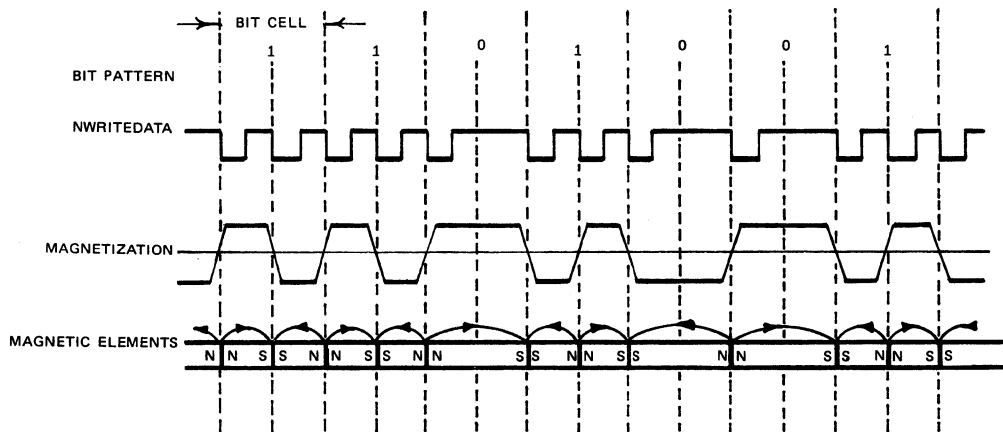

Figure 1-3
FM Recording Magnetization Profiles

1.16.6.1 Data Recording

The write electronics consist of a Write Current Source, a Write Waveform Generator, an Erase Current Source, the Trim Erase Control Logic, and the Head Select Logic (see Figure 1-2).

The read/write winding on the magnetic head is center-tapped. During a write operation, current from the Write Current Source flows in alternate halves of the winding, under control of the Write Waveform Generator.

The conditions required for recording, i.e., unit ready, must be established by the user system, as follows:

1. Drive speed stabilization occurs 250 msec after the drive motor is started.
2. Subsequent to any step operation, the positioner must be allowed to settle. This requires 18 msec after the last step pulse is initiated, i.e., 3 msec for the step motion and 15 msec for settling.
3. The foregoing operations can be overlapped, if required.

Figure 1-4 illustrates the timing diagram for a write operation. At $t=0$, when the unit is ready, the Write Enable interface line goes true. This enables the Write Current Source.

The Trim Erase control goes true 390 msec after the Write Enable interface line since the trim erase gaps are behind the read/write gap. It should be noted that this value is optimized between the requirements at Track 00 and at Track 79 (96 TPI) or Track 77 (100 TPI), so that the effect of the trim erase gaps on previous information is minimized.

Figure 1-4 shows the information on the Write Data interface line and the output of the Write Waveform Generator, which toggles on the leading edge of every Write Data pulse.

A minimum of 4 usec and a maximum of 8 usec between Write Enable going true and the first Write Data pulse is required only if faithful reproduction of the first Write Data Transition is significant.

At the end of recording, at least one additional pulse on the Write Data line must be inserted after the last significant Write Data pulse to avoid excessive peak shift effects.

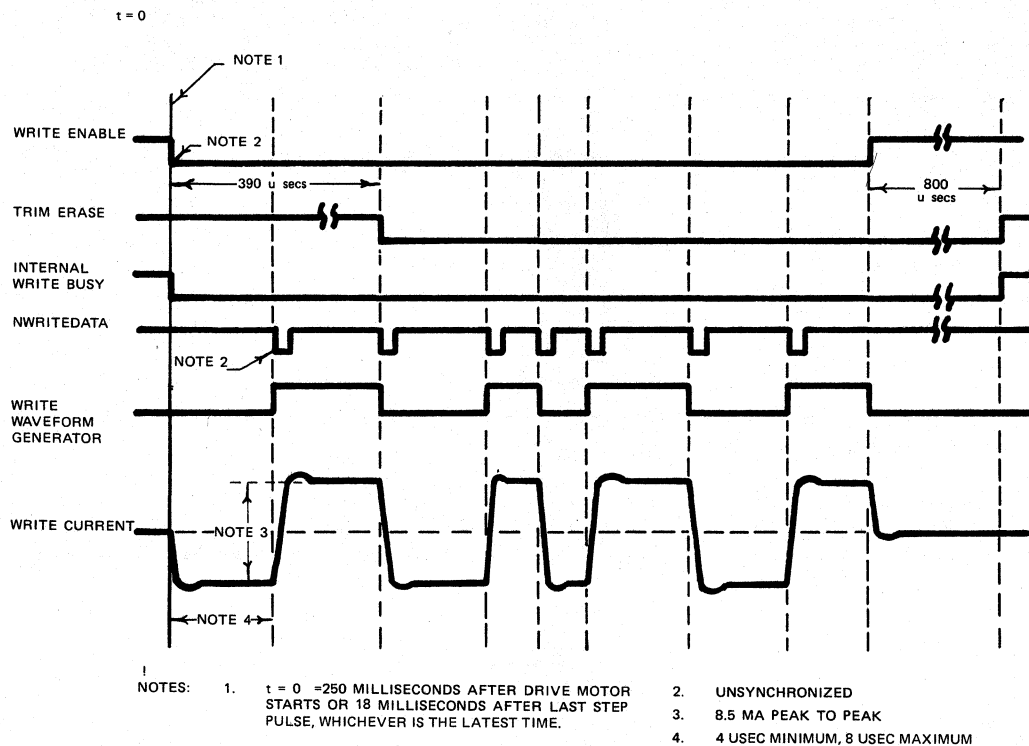

Figure 1-4
Write Operation Timing Diagram

The duration of a write operation is from the true going edge of Write Enable to the false going edge of Trim Erase. This is indicated by the Internal Write Busy waveform shown (see Figure 1-4).

The Read electronics consist of:

1. Read Switch/Side Select
2. Read Amplifier
3. Filter
4. Differentiator
5. Comparator and Digitizer

The Read switch is used to isolate the Read Amplifier from the voltage excursion across the magnetic head during a Write operation. The side select is used to enable one of the Read/Write/Erase heads.

The disk drive must be in a ready condition before reading can begin. As with the data recording operation, this ready condition must be established by the user system. In addition to the requirements established in this section, a 100 usec delay must exist from the trailing edge of the Trim Erase signal to allow the Read Amplifier to settle after the transient caused by the Read switch returning to the Read mode.

The output signal from the Read/Write head is amplified by a Read Amplifier and filtered by a linear phase filter to remove noise (see Figure 1-5). The linear output from the filter is passed to the Differentiator, which generates a waveform whose zero crossovers correspond to the peaks of the Read signal. Then, this signal is fed to the Comparator and the Digitizer circuitry.

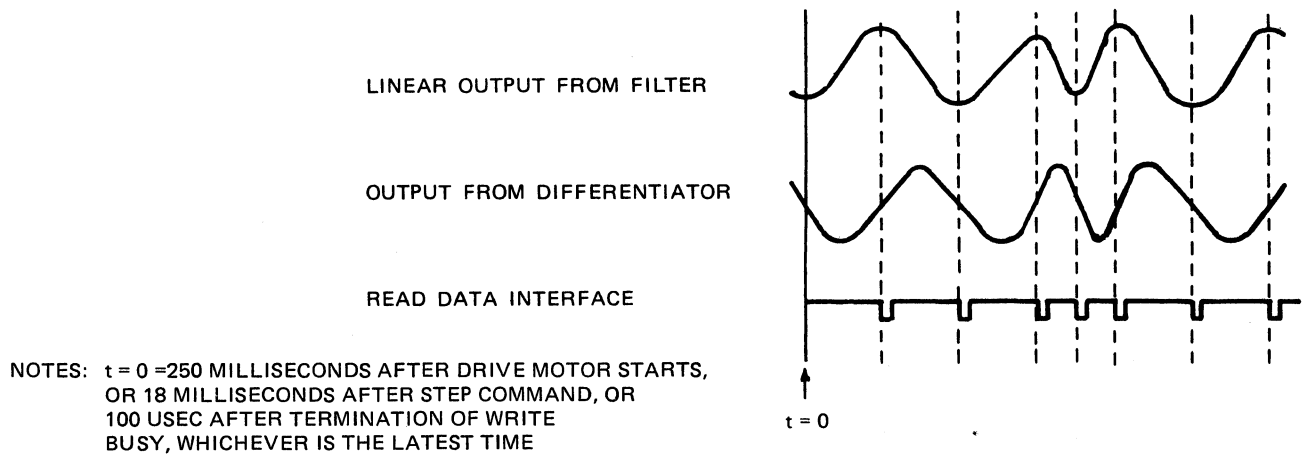

Figure 1-5
Read Timing Diagram

The Comparator and the Digitizer circuitry generate a 1 usec Read Data pulse, corresponding to each peak of the Read signal. Then, the Composite Read Data signal is sent to the user system via the Read Data interface line.

1.17 INTERFACE ELECTRONICS

All interface signals are TTL-compatible. Logic true (low) is +0.4V (maximum); logic false (high) is +2.4V (minimum). The maximum interface cable length is ten (10) feet.

It is recommended that the interface cable be flat ribbon cable, having a characteristic impedance of 100 ohms, or equivalent twisted pairs.

1.17.1 Interface Connector Pin Assignments, J1/P1

The interface connector pin assignments, J1/P1, are listed in Table 1-2.

1.17.2 Power Connector Pin Assignments

The power connector pin assignments are listed in Table 1-3.

1.18 OPTION SELECT

1.18.1 Input Line Terminations

The disk drive has the capability of terminating the following input lines:

1. Motor On
2. Direction Select
3. Step
4. Write Data

TABLE 1-2
INTERFACE CONNECTOR PIN ASSIGNMENTS, J1/P1

CONTROLLER-TO-DISK DRIVE		
Ground	Signal	Mnemonic Description
1	2	Connector Clamp
3	4	Spare
5	6	Select 3 (NDS3)
9	10	Select 0 (NDS0)
11	12	Select 1 (NDS1)
13	14	Select 2 (NDS2)
15	16	Drive Motor Enable (NMOTOR ON)
17	18	Direction (DIR)
19	20	Step (NSTEP)
21	22	Write Data (NWRITE DATA)
23	24	Write Gate (NWRITE ENABLE)
31	32	Side Select (NSIDE SELECT)
33	34	Connector Clamp
DISK DRIVE-TO-CONTROLLER		
Ground	Signal	Mnemonic Description
7	8	Index (NINDEX / SECTOR)
25	26	Track 00 (NTRK 00)
27	28	Write Protect (NWRITE PROTECT)
29	30	Read Data (NREAD DATA)

TABLE 1-3
POWER CONNECTOR PIN ASSIGNMENTS

Pin	Supply Voltage
1	+ 12 VDC
2	Return (+ 12 VDC)
3	Return (+ 5 VDC)
4	+ 5 VDC

- 5. Side Select
- 6. Write Gate

These input lines are terminated through a 150 ohm resistor pack that is installed in the dip socket located at IC location 2F. In a single-drive system, this resistor pack should be kept in place to provide the proper terminations. In a multiple-drive system (Program Shunt position MX open), only the last drive on the interface is to be terminated. All other drives on the interface must have the resistor pack removed (see Figure 1-6).

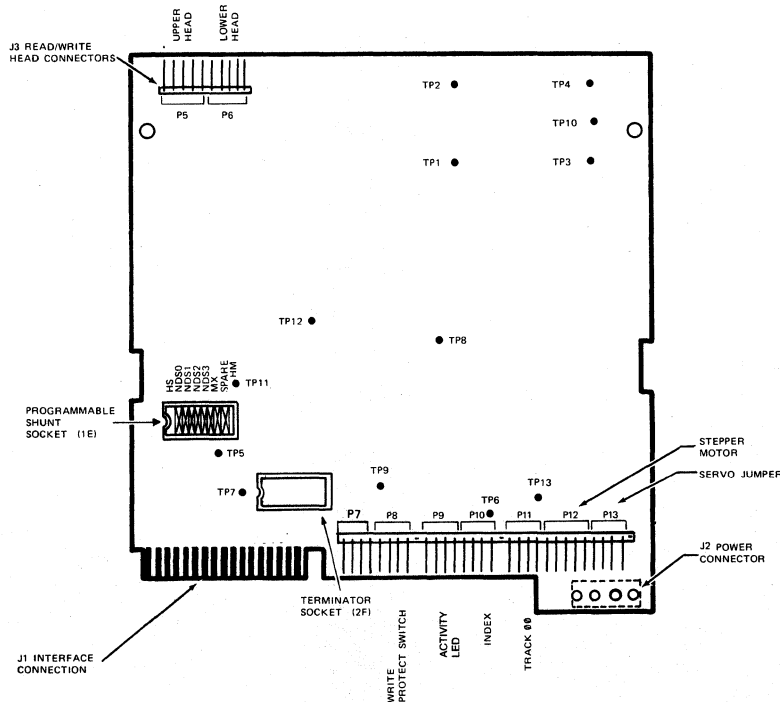

Figure 1-6
Logic Printed Circuit Board Assembly

1.18.2 Drive Select

As shipped from the factory, the disk drive is configured to operate in a single-drive system. The user can easily modify it to operate with other drives in a multiplexed, multiple-drive system. The user can activate the multiplex option by cutting the MX position of the programmable shunt, located at IC location 1E, which allows the input/output (I/O) lines to be multiplexed.

The Select lines provide a means of selecting and deselecting a disk drive. These four (4) lines — NDS0 through NDS3 — select one of the four (4) disk drives attached to the controller.

When the signal logic level is true (low), the disk drive electronics are activated and the disk drive is conditioned to respond to Step or to Read/Write commands. When the signal logic level is false (high), the Input Control lines and the Output Status lines are disabled.

A Select line must remain stable in the true (low) state until the execution of a Step or Read/Write command is completed.

The disk drive address is determined by a Select Shunt on the PCBA. Select lines zero-through-three (0-3) provide a means of daisy chaining a maximum of four (4) disk drives to a controller. Only one (1) line can be true (low) at a time. An undefined operation might result if two or more units are assigned the same address or if two or more Select lines are in the true (low) state simultaneously (see Figure 1-6).

The Program Shunt is AMP Part Number 435704-7. The Program Shunt positions can be cut using AMP's Part Number 435705. The Program Shunt is installed in a dip socket. At the user's option, the Program Shunt may be removed and replaced by a dip switch. In addition, the user may choose to have the Program Shunts preprogrammed and/or color coded by AMP. For this service, contact your local AMP representative.

1.19 POWER SAVE OPTION

As shipped from the factory, the disk drive is configured to operate in a single-drive system. Jumper (0 ohm resistor) R51 maintains the power to the stepper motor whether or not the disk drive is selected. However, the jumper in position R51 may be moved to position R50. R50 removes the power to the stepper motor when the disk drive is not selected, for a savings approximately equal to 3.8 watts per drive. When R50 is used, at the time the disk drive is reselected, the user must ensure the track location.

1.20 AGENCY APPROVALS

The entire family of Tandon's TM100 disk drives have been approved by the Underwriters Laboratories and the Canadian Standards Association.

SECTION II MAINTENANCE CHECKS AND ADJUSTMENTS

2. INTRODUCTION

This section is designed for the use of the OEM Repair Department. It contains the maintenance checks and adjustments that are used during the normal life of the disk drive.

Before applying power to the unit or doing any checks or adjustments, visually inspect the disk drive to ensure that it has no missing or broken parts.

The following equipment is required for checks and adjustments:

1. A dual-channel, wideband oscilloscope (HP 1740A or equivalent).
2. An exerciser or software routine capable of stepping the disk drive to any track, selecting the upper or lower head, and writing a 1F (all zeros if FM) or a 2F (all ones if FM) pattern.
3. A Phillips screwdriver.
4. A .050" Allen wrench.
5. A flat blade screwdriver.
6. A 3/16" nut driver.
7. A work diskette.
8. An alignment diskette (Dysan P/N 802020, Model Number 206-30).
9. A 50-gram dynamometer.
10. A 7/64" Allen wrench.

2.1 DRIVE MOTOR CHECKS AND ADJUSTMENTS

The long-term drive motor speed adjustment ensures that the motor's speed is within the range of tolerance specified. The motor speed specification is 300 rpm \pm 1.5%.

2.1.1 Long-Term Drive Motor Speed Checks and Adjustment

2.1.1.1 Preliminary checks required:

Verify power: +12 VDC \pm .6 V
 +5 VDC \pm .25 V

2.1.1.2 Apply power to the disk drive.

2.1.1.3 Activate the drive motor on the interface line.

2.1.1.4 Insert a work diskette.

2.1.1.5 Observe the speed disk on the spindle pulley under fluorescent lighting (see Figure 2-1).

2.1.1.6 Adjust R4, located on the Servo PCBA, until the applicable pattern on the pulley appears stationary (see Figure 2-2).

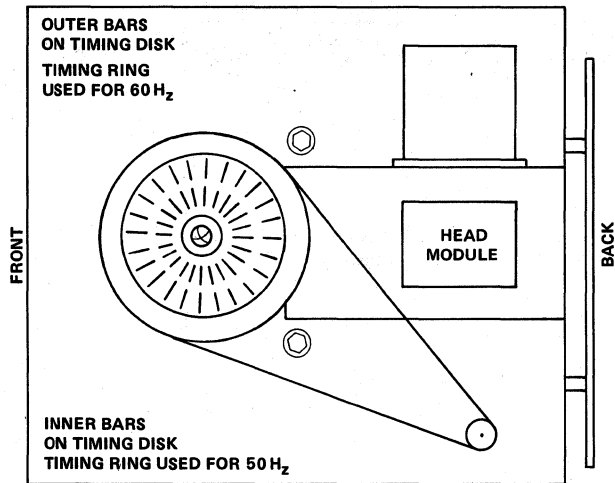

Figure 2-1
Bottom View of The TM100 Disk Drive

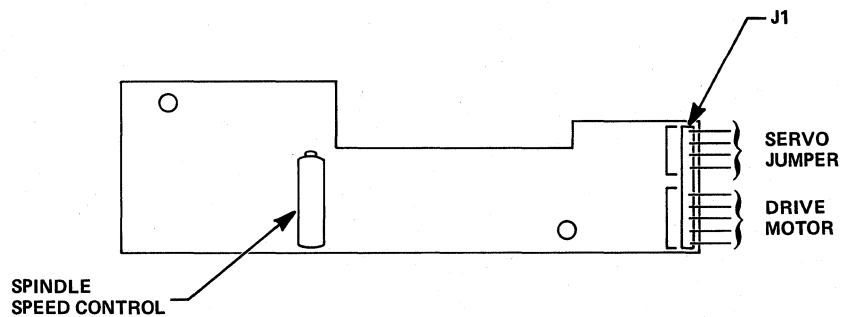

Figure 2-2
Location of R4 Speed Control Pot

2.1.1.7 If the drive motor's speed cannot be adjusted, see Section IV (Troubleshooting Guide).

2.1.2 Instantaneous Speed Variation Check

The Instantaneous Speed Variation (ISV) checks the smoothness of the spindle's rotation. This is determined by the disk drive system, which consists of the drive motor, drive belt, pulleys, hub, and hub bearings.

2.1.2.1 With the work diskette inserted, write a 2F (all ones) pattern on any track.

2.1.2.2 Connect a wideband oscilloscope to Test Point 5 on the logic PCBA, using Test Point 6 as a ground.

2.1.2.3 Set up a dual-channel, wideband oscilloscope, as follows:

Vertical Display: 2 Volts Per Division

Time Base: 1 usec Per Division

Internal Trigger: Positive Edge

2.1.2.4 Observe the following pattern (see Figure 2-3).

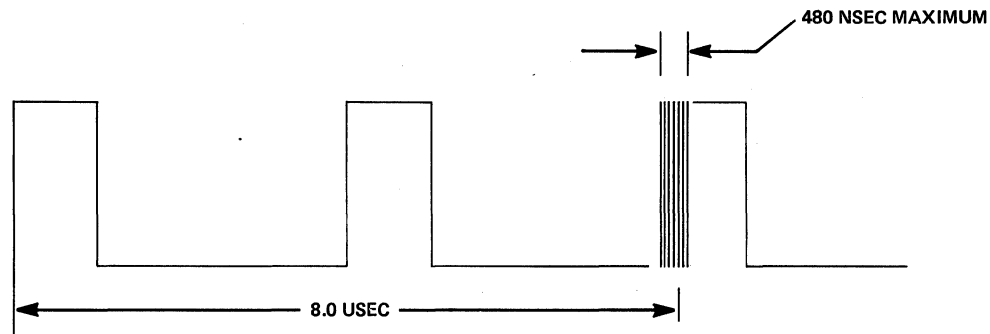

Figure 2-3
ISV Pulse Pattern

- 2.1.2.5 Measure the amount of jitter present on the leading edge of the third pulse (see Figure 2-3). Jitter on the third pulse of greater than ± 240 nsec (480 nsec edge-to-edge) indicates excessive ISV.
- 2.1.2.6 Confirm the measurement (see Section 2.1.2.5) with a second work diskette.
- 2.1.2.7 If the ISV is excessive, replace the drive belt (see Section 5.1), and remeasure the Instantaneous Speed Variation (ISV) (see Section 2.1.2).
- 2.1.2.8 If the ISV is excessive, replace the drive motor (see Section 5.10), and remeasure the ISV (see Section 2.1.2).
- 2.1.2.9 If replacing the drive belt and the drive motor does not cure the excessive ISV, see Section IV (Troubleshooting Guide).

2.2 CATS EYE ALIGNMENT CHECK AND ADJUSTMENT

The Cats Eye (CE) alignment procedure locates the magnetic read/write head at the proper radial distance from the hub center line, thus ensuring that the track location is accurate (see Figure 2-4). This adjustment is necessary only after service or if diskette interchange problems are suspected.

2.2.1 CE Alignment Check

2.2.1.1 Set up a dual-channel, wideband oscilloscope, as follows:

Channel A, Test Point 1; Channel B, Test Point 2

Ground: Test Point 10

Read Differentially: A plus B, B inverted

Time Base: 20 msec Per Division

External Trigger: Test Point 7, Positive Edge

Vertical Display: 0.1 Volt Per Division

2.2.1.2 Apply power to the disk drive.

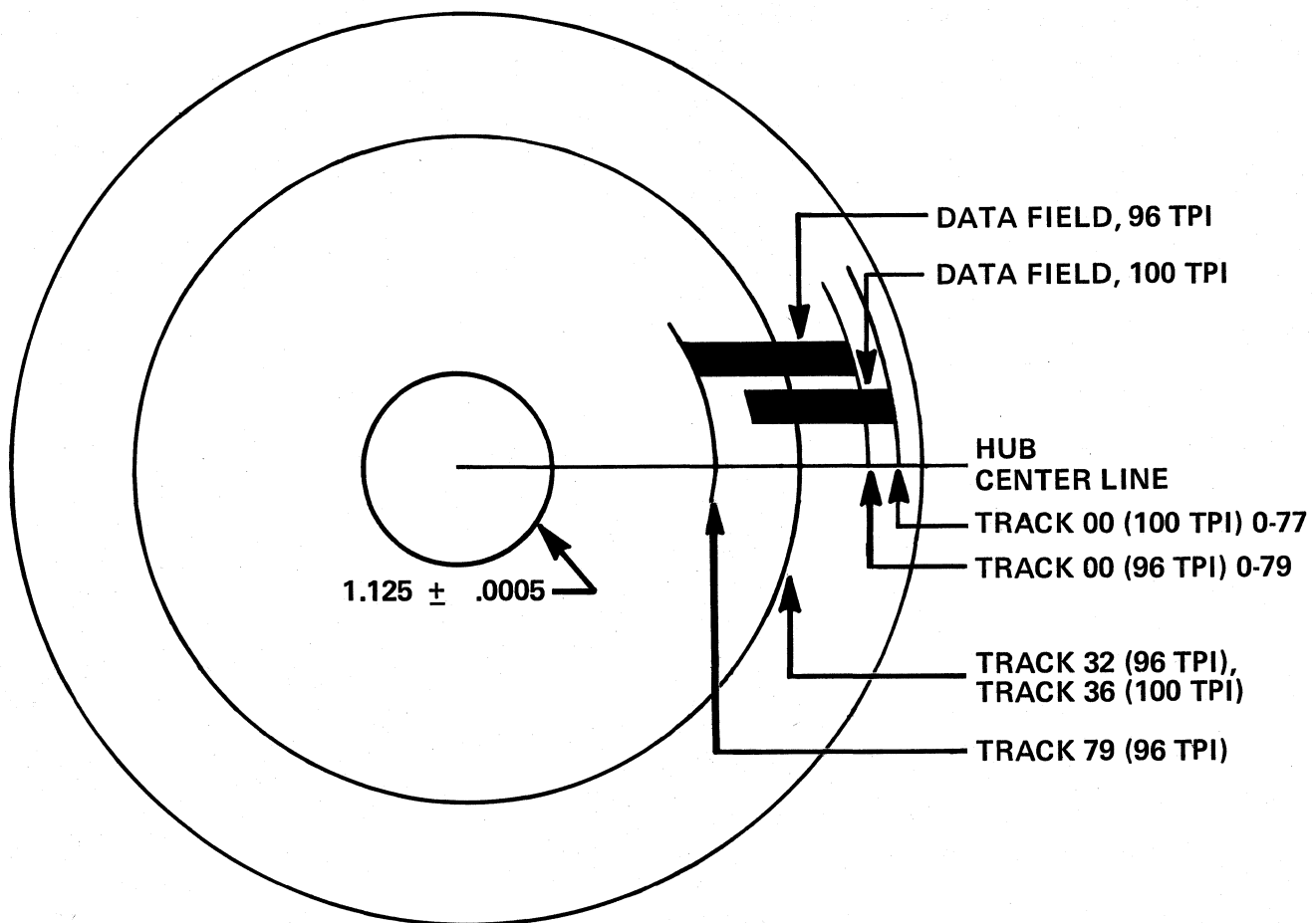
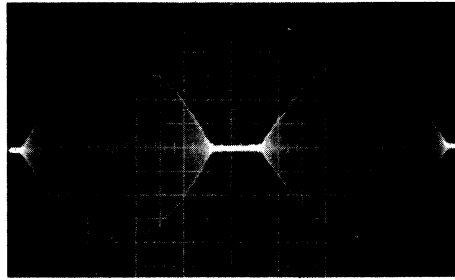

Figure 2-4
Hub Center Line and Track Locations

- 2.2.1.3 Select the disk drive with the interface logic.
- 2.2.1.4 Insert a Cats Eye alignment diskette into the disk drive.
- 2.2.1.5 Select Head 00, the lower head.
- 2.2.1.6 Read Track 32 (96 TPI) or 36 (100 TPI) for Cats Eye alignment of the lower head.
- 2.2.1.7 Adjust the dual-channel, wideband oscilloscope to observe a Cats Eye pattern (see Figure 2-5).
- 2.2.1.8 Verify that the smaller of the two (2) Cats Eye patterns is not less than 75% in amplitude of the other one.



EQUAL AMPLITUDE
ON TRACK 32 FOR 96TPI
AND TRACK 36 FOR
100TPI.

TIME SCALE = 20 ms/DIV.

Figure 2-5
Cats Eye Pattern

NOTE

The 75% figure is for use with an alignment diskette that has been verified against a standard alignment diskette.

- 2.2.1.9 Step the disk drive to Track 00; then, step it back to Track 32 or 36.
- 2.2.1.10 Reverify the Cats Eye pattern.
- 2.2.1.11 Step the disk drive to Track 52 or a higher track; then, step it back to Track 32 or 36.
- 2.2.1.12 Reverify the Cats Eye pattern.
- 2.2.1.13 Switch to Head 01, the upper head, if applicable.
- 2.2.1.14 Read Track 32 (96 TPI) or 36 (100 TPI) to verify the alignment of the upper head.
- 2.2.1.15 Verify the Cats Eye pattern.
- 2.2.1.16 Step the disk drive to Track 00; then, step it back to Track 32 (96 TPI) or 36 (100 TPI).
- 2.2.1.17 Reverify the Cats Eye pattern.
- 2.2.1.18 If all of the checks listed above verify or reverify, the Cats Eye alignment of the head is acceptable.
- 2.2.1.19 If any of the checks listed above does not meet the conditions stated in Section 2.2.1.8, the drive must be adjusted.

2.2.2 Head Adjustment

- 2.2.2.1 Turn the three (3) module cap screws – two of which are located underneath and one of which is located at the back of the disk drive in the center – counterclockwise one-half (1/2) turn (see Figure 2-6) with a 7/64" Allen wrench.

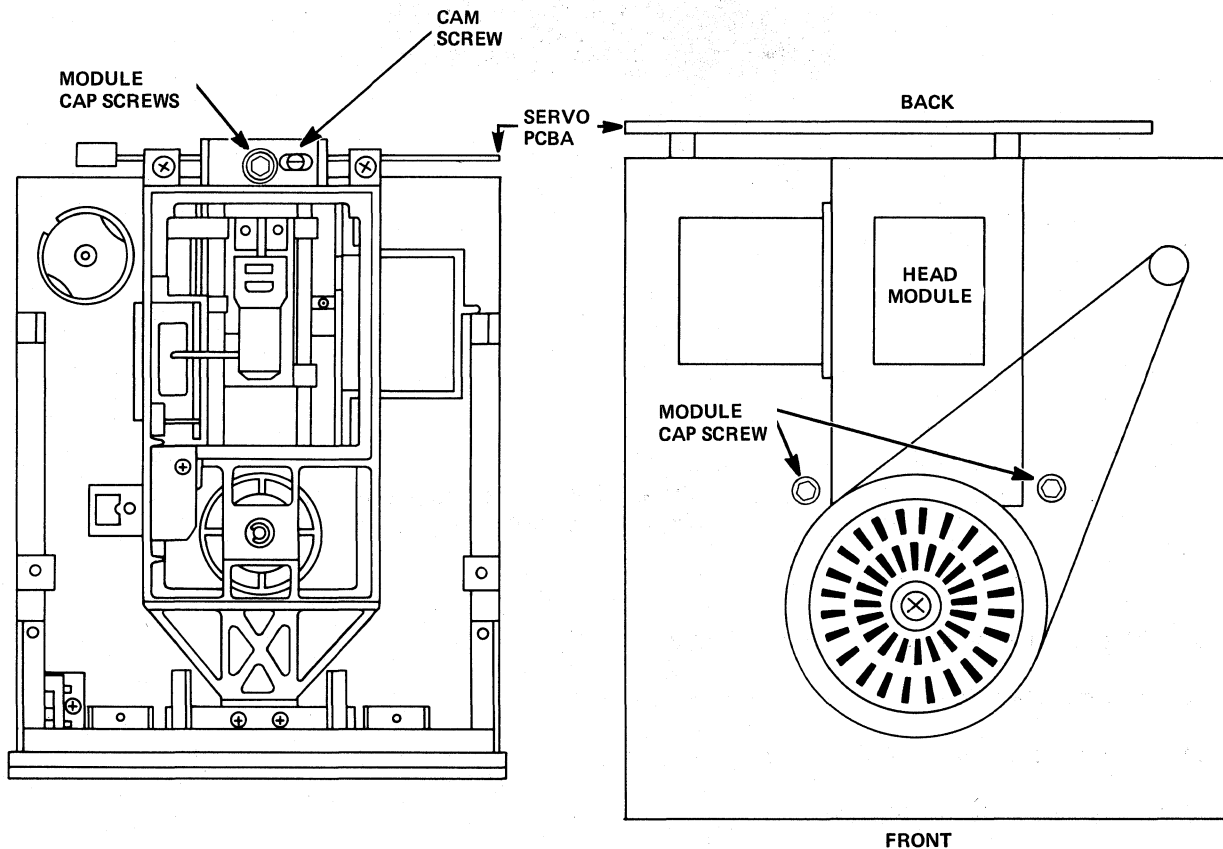

Figure 2-6
Head Module Cap and Cam Screws

- 2.2.2.2 Observe the Cats Eye pattern at the magnetic head that is farthest out of alignment.
- 2.2.2.3 Using a flat blade screwdriver, turn the cam screw until the Cats Eye pattern meets the conditions stated in Section 2.2.1.8.
- 2.2.2.4 Tighten the three (3) module cap screws (see Figure 2-6) with a 7/64" Allen wrench.
- 2.2.2.5 Reverify the Cats Eye alignment (see Section 2.2.1).
- ## 2.2.3 Track 00 Stop Adjustment
- 2.2.3.1 The Track 00 stop screw does not allow the carriage assembly to seek to a position lower than Track 00.

- 2.2.3.2 Apply power to the disk drive.
- 2.2.3.3 Select the disk drive with the control logic.
- 2.2.3.4 Monitor the output at Test Points 1 and 2.
- 2.2.3.5 Set the dual-channel, wideband oscilloscope to read differentially, A and B, B inverted.
- 2.2.3.6 Insert an alignment diskette.
- 2.2.3.7 Read the information at Track 00.
- 2.2.3.8 Turn the Track 00 stop screw counterclockwise two (2) turns with a .050" Allen wrench (see Figure 2-7).

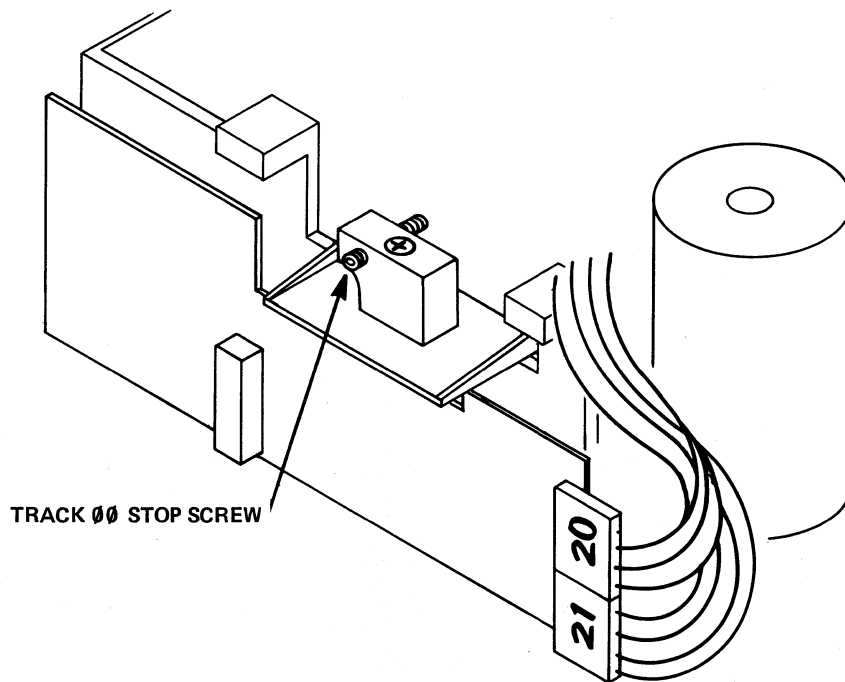

Figure 2-7
Track 00 Stop

- 2.2.3.9 Slowly turn the Track 00 stop screw clockwise until the output amplitude shown on the dual-channel, wideband oscilloscope begins to decrease.
- 2.2.3.10 Turn the Track 00 stop screw counterclockwise until the amplitude stops increasing.
- 2.2.3.11 Turn the Track 00 stop screw counterclockwise an additional one-eighth (1/8) turn.

2.3 INDEX FOUR-POINT ALIGNMENT CHECK AND ADJUSTMENT

The index adjustment changes the time period from the index pulse to the start of the data. The adjustment should be checked after the disk drive has been aligned (see Section 2.1.1) or when diskette interchange errors are suspected.

2.3.1 Index Four-Point Alignment Check

2.3.1.1 Check the speed of the drive motor.

2.3.1.2 Apply power to the disk drive.

2.3.1.3 Select the disk drive with the control logic.

2.3.1.4 Set up a dual-channel, wideband oscilloscope, as follows:

External Trigger: Test Point 7, Positive Edge

Read Differentially: A plus B, B inverted

Channel A, Test Point 1; Channel B, Test Point 2

Time Base: 50 usec Per Division

Vertical Display: 0.1 Volt Per Division

2.3.1.5 Insert an alignment diskette.

2.3.1.6 Select Track 8 (96 TPI) or Track 11 (100 TPI).

2.3.1.7 Select Head 00, the lower head.

2.3.1.8 Read the trigger point (index) to the start of the first data pulse width (see Figure 2-8).

NOTE

The specification is 200 usec \pm 100 usec.

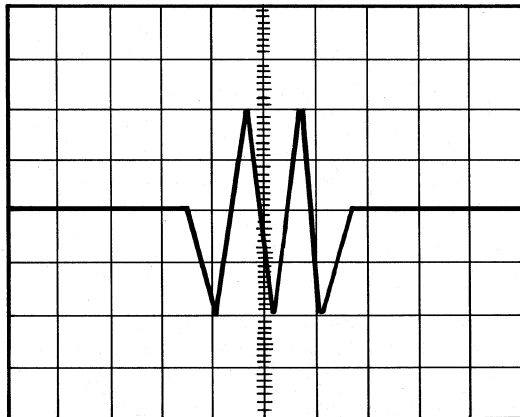

TIME SCALE: 50 USEC PER DIVISION

Figure 2-8
Index-To-Data Pulse

- 2.3.1.9 Select Track 56 (96 TPI) or Track 61 (100 TPI).
- 2.3.1.10 Reverify the index-to-data burst timing.
- 2.3.1.11 For double-sided disk drives, if Head 00, the lower head, meets the specification, check Head 01, the upper head, and repeat step 2.3.1.8.

NOTES

Head 01 should meet the same specification.

If the index measurements meet the specification, the index sensor does not need to be adjusted.

- 2.3.1.12 If either Head 00 or Head 01 does not meet the specification, adjust the index sensor (see Section 2.3.2.1).
- 2.3.1.13 Recheck all indexes after they are adjusted.
- 2.3.2 Index Adjustment
 - 2.3.2.1 From the bottom of the chassis, loosen the index sensor's retaining screw counterclockwise one-quarter (1/4) turn (see Figure 2-9) with a Phillips screwdriver.

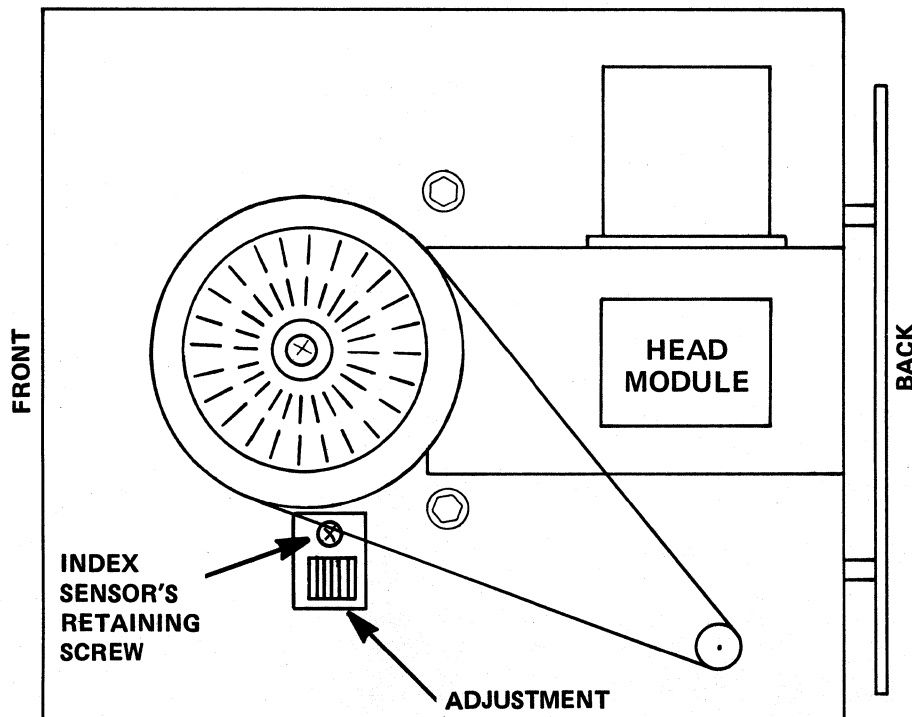

Figure 2-9
Index Sensor's Retaining Screw and Adjustment

- 2.3.2.2 Adjust the index sensor with a flat blade screwdriver until the data pulse begins 200 usec \pm 100 usec from the trigger point.

2.3.2.3 Tighten the index sensor's retaining screw with a Phillips screwdriver.

2.3.2.4 Reverify all indexes.

2.4 COMPLIANCE CHECK AND ADJUSTMENT

Compliance is the maximized output of the magnetic head when the pressure of the felt pressure pad is centered over the read/write gap. For single-sided disk drives, a compliance check and adjustment can be made in the field. For double-sided disk drives, a compliance check and adjustment must be made at the factory.

2.4.1 Compliance Check

2.4.1.1 Rest the disk drive on its cast base.

2.4.1.2 Remove the two (2) screws that attach the Logic PCBA to the guide rails.

2.4.1.3 Lift out the Logic PCBA, and lay it on the disk drive.

NOTE

This allows the operator to reach inside the disk drive to reach the upper arm.

2.4.1.4 Apply power to the disk drive.

2.4.1.5 Select the disk drive with the control logic.

2.4.1.6 Insert a work diskette.

2.4.1.7 Write information on Track 79 (96 TPI) or Track 77 (100 TPI).

2.4.1.8 Read the information on Track 79 or 77.

2.4.1.9 Set up a dual-channel, wideband oscilloscope, as follows:

Channel A, Test Point 1; Channel B, Test Point 2

Ground: Test Point 10

Vertical Display: 0.1 Volt Per Division

Read Differentially: A and B, B inverted

Time Base: 10 msec Per Division

External Trigger: Test Point 7, Positive Edge

2.4.1.10 Read the output voltage.

2.4.1.11 With a 50-gram dynamometer, carefully apply fifteen (15) grams pressure to the upper arm, increasing the load force on the head.

Note

Fifteen grams is about the weight of a quarter.

2.4.1.12 If the output shown on the dual-channel, wideband oscilloscope increases by more than ten percent (10%), adjust the compliance.

2.4.2 Compliance Adjustment

The compliance is adjusted by using the same procedure as is used in the compliance check (see Section 2.4.1).

2.4.2.1 Turn the two (2) nuts that attach the upper arm to the carriage assembly (see Figure 2-10) counterclockwise one-quarter (1/4) turn with a 3/16" nut driver.

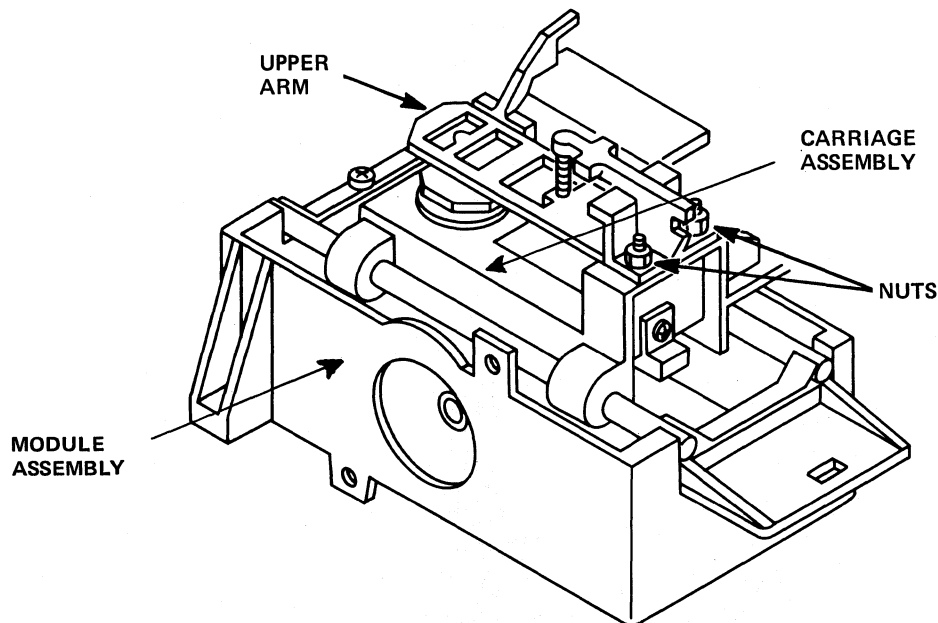

Figure 2-10
Upper Arm and Nuts

2.4.2.2 While monitoring the output, move the upper arm around the axis of the head until the output is the highest.

- 2.4.2.3 Turn the two (2) nuts that attach the upper arm to the carriage assembly clockwise with a 3/16" nut driver while holding the arm in the highest position.
- 2.4.2.4 Reverify the compliance of the magnetic head.
- 2.4.2.5 If the compliance cannot be adjusted, replace the upper arm (see Section 5.13).

2.5 WRITE PROTECT SWITCH ADJUSTMENT PROCEDURE

- 2.5.1 Connect the disk drive to an exercisor or computer with a direct monitor of write printed output (Pin 28 of J1) or, with no power to the disk drive, disconnect Plug 8, and check the continuity with an ohmeter.
- 2.5.2 With a non-write protected diskette inserted, verify that there is no continuity between the two (2) wires of Plug 8 or that there is a non-write protected output to the exercisor or computer, i.e., a high at Pin 28 of J1.
- 2.5.3 With a write protected diskette inserted, verify that there is continuity between the two (2) wires of Plug 8 or that there is a write-protect true output to the controller or exercisor (low at Pin 28 of J1).

Note

A defective circuit board can be responsible for a write protect problem. Test Point 9 should be high for a write-protected disk drive, and low for a non-write protected disk drive.

- 2.5.4 To adjust the write protect switch, loosen the screw that holds the switch to the bracket on the side farthest from the front of the disk drive. Move the switch up or down, as required, to satisfy the condition of Section 2.5.2 and Section 2.5.3 above (see Figure 2-11).

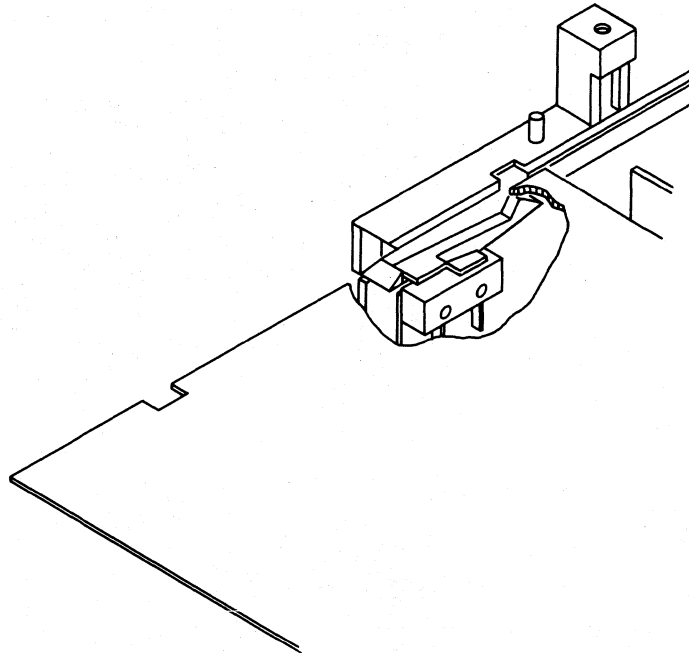

Figure 2-11
Write Protect Switch Adjustment

2.6 TRACK 00 SENSOR CHECK AND ADJUSTMENT

The Track 00 sensor provides a signal that identifies Track 00 to the logic electronics. The logic electronics disable the step-in function when Track 00 is reached. In addition, a Track 00 signal is sent to the controller on Pin 26 of the interface.

- 2.6.1 Apply power to the disk drive.
- 2.6.2 Insert a Cats Eye alignment diskette into the disk drive.
- 2.6.3 Close the front door.
- 2.6.4 Step the carriage to the radial alignment track.
- 2.6.5 Confirm the position by observing the CE pattern.
- 2.6.6 Loosen the retaining screw on the base of the Track 00 bracket.
- 2.6.7 Retighten the retaining screw slightly to provide some friction on the bracket.
- 2.6.8 Rotate the Track 00 adjustment screw, located at the rear of the chassis, counterclockwise as far as it can go without forcing it.
- 2.6.9 Step the carriage back to Track 01 from the radial alignment track taking care not to restore it back to Track 00.
- 2.6.10 Rotate the Track 00 adjustment screw clockwise - very slowly - until the voltage at Pin 2 of Connector P11 is at least 2.5 volts with the carriage at Track 01, and a maximum of 0.8 volt with the carriage at Track 02.
- 2.6.11 Retighten the retaining screw.

SECTION III PRINTED CIRCUIT BOARD OPERATION

3. INTRODUCTION

This section contains the interface description and the mechanical and the electrical adjustments necessary for the TM100 family of disk drives. In addition, Section 3.2 and Section 3.3 contain schematic diagrams of the Logic Printed Circuit Board Assembly (PCBA) installed in the disk drive. Section 3.4 contains a schematic diagram of the Servo PCBA installed in the disk drive.

3.1 EXPLANATION OF SYMBOLS AND ABBREVIATIONS

Table 3-1 contains a list of major symbols and abbreviations found on the schematic diagrams in this section. In addition, in the functional and circuit descriptions, a specification like "N MOTOR ON" stands for the negative true motor on signal.

3.2 PHYSICAL DESCRIPTION OF THE LOGIC PCBA

The Logic PCBA is approximately 146 mm (5.75 inches) long by 146 mm (5.75 inches) wide. Figure 3-1 contains an illustration of the placement of test points and connectors.

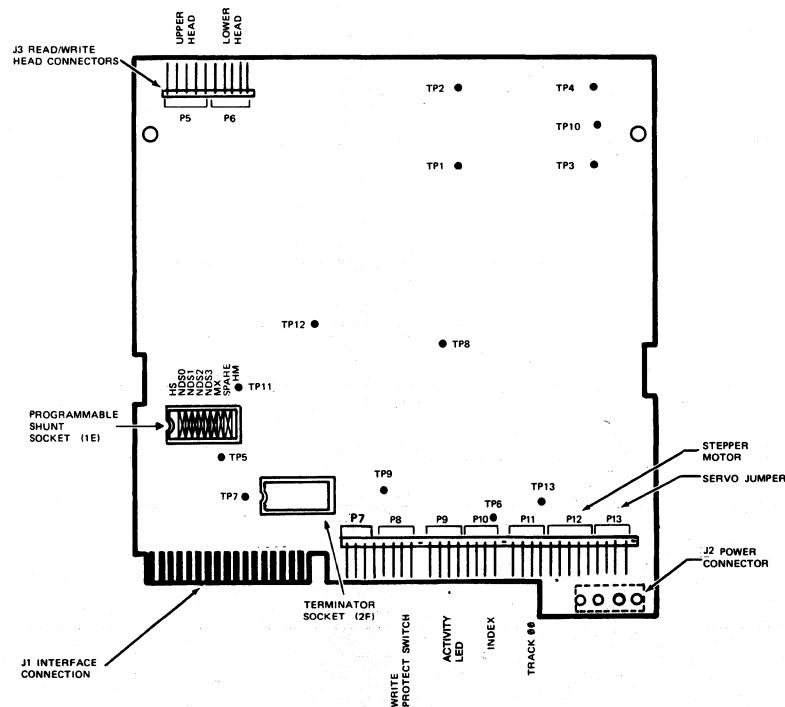

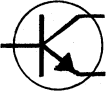









Figure 3-1
Logic PCBA

TABLE 3-1
SYMBOLS AND ABBREVIATIONS

Symbol	Meaning
	Erase Coils
	Read/Write Coils
	Transistor
	Photo Transistor
	Driver
	Driver, Open Collector Output
	Driver, Inverted
	Inverter, Open Collector Output
	"AND" Gate, Open Collector Output
	"AND" Gate, Inverted

3.3 INTERFACE ELECTRONICS SPECIFICATIONS

All interface signals are TTL compatible. Logic true (low) is +0.4 V (minimum). Figure 3-2 illustrates the interface configuration. The maximum interface cable length is ten (10) feet.

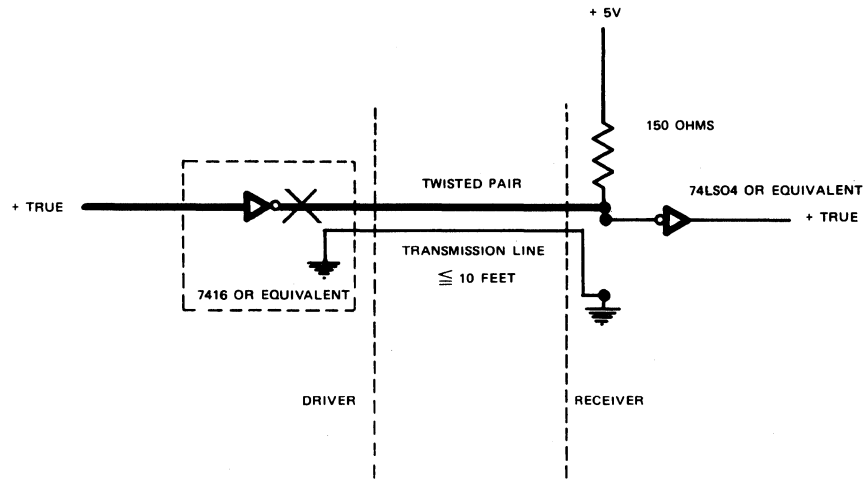

Figure 3-2
Interface Configuration

It is recommended that the interface cable be flat ribbon cable, with a characteristic impedance of 100 ohms (or equivalent twisted pairs).

Interface connector pin assignments and power connector pin assignments are given in Table 3-2 and Table 3-3.

3.3.1 Input Control Lines

TABLE 3-2
INTERFACE CONNECTOR PIN ASSIGNMENTS, J1/P1

CONTROLLER-TO-DISK DRIVE		
Ground	Signal	Mnemonic Description
1	2	Connector Clamp
3	4	Spare
5	6	Select 3 (NDS3)
9	10	Select 0 (NDS0)
11	12	Select 1 (NDS1)
13	14	Select 2 (NDS2)
15	16	Drive Motor Enable (NMOTOR ON)
17	18	Direction (DIR)
19	20	Step (NSTEP)
21	22	Write Data (NWRITE DATA)
23	24	Write Gate (NWRITE ENABLE)
31	32	Side Select (NSIDE SELECT)
33	34	Connector Clamp

DISK DRIVE-TO-CONTROLLER		
Ground	Signal	Mnemonic Description
7	8	Index (NINDEX / SECTOR)
25	26	Track 00 (NTRK 00)
27	28	Write Protect (NWRITE PROTECT)
29	30	Read Data (NREAD DATA)

TABLE 3-3
POWER CONNECTOR PIN ASSIGNMENTS

Pin	Supply Voltage
1	+ 12 VDC
2	Return (+ 12 VDC)
3	Return (+ 5 VDC)
4	+ 5 VDC

3.3.1.1 Select Lines (NDS0-NDS3)

Functional Description

The select lines (see Figure 3-3) provide a means of selecting and deselecting a disk drive. These four (4) lines (NDS0-NDS3 standard) select one (1) of the four (4) disk drives attached to the controller. When the signal logic level is true (low), the disk drive electronics are activated and the disk drive is conditioned to respond to Step or Read/Write commands. When the logic level is false (high), the input control lines and output status lines are disabled.

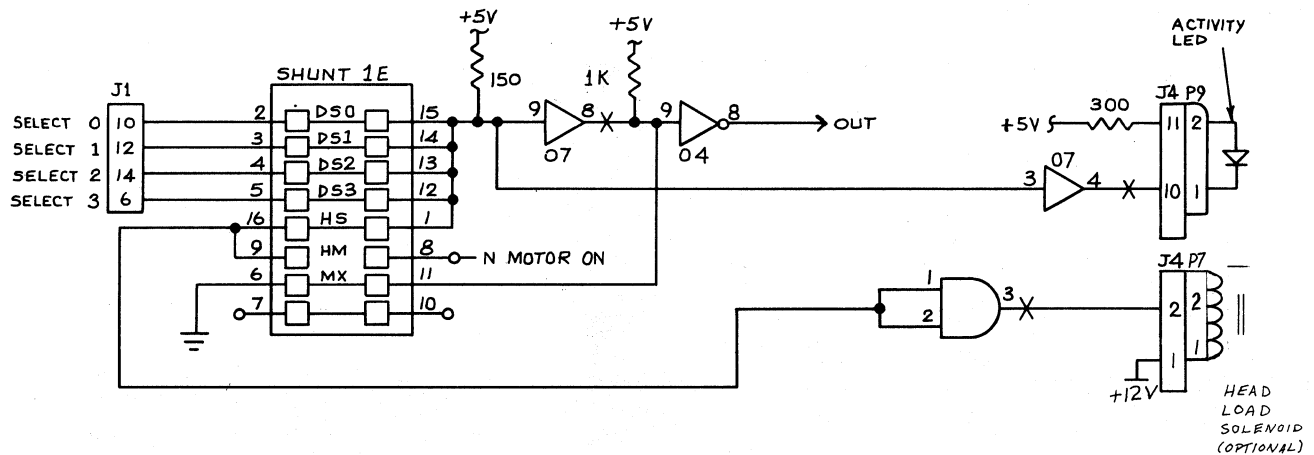

Figure 3-3
Select Lines Schematic Diagram

A select line must remain stable in the true (low) state until the execution of a Step or Read/Write command is completed.

The disk drive address is determined by a Select Shunt on the PCBA. Select lines 0-3 provide a means of daisy chaining a maximum of four (4) disk drives to a controller. Only one line can be true (low) at a time. An undefined operation might result if two or more units are assigned the same address or if two or more select lines are in the true (low) state simultaneously.

When the disk drive is selected, the activity (front panel) LED will be on.

In a multiple disk drive system, the MX jumper must be cut. If not, the disk drive will always be active.

Circuit Description

A 150 ohm resistor holds the output of the appropriate select line high until the line is driven low. This is buffered through two integrated circuits and enables the drive electronics. Note that when the MX jumper is not cut, the disk drive is always enabled (Pin 3D-8 high).

The front panel LED is driven by the select logic through an integrated circuit. Note that if the disk drive is not selected through the select jumpers, and the MX jumper is not cut, the drive electronics will be active but the front panel LED will not be on.

Normally, Tandon Corporation's disk drives have no head load solenoid. Hence, the HS and the HM jumpers are not used. In no case should both the HS and the HM jumpers be in since this would allow interaction between the Select signal and the Motor On signal. However, if the optional head load solenoid is installed, it is selected by either the HS or the HM jumper. The HS jumper enables the head load solenoid driver when the unit is selected. The HM jumper enables the head load solenoid driver when the Motor On signal to the disk drive is true. Test Point 11 is low when the head load solenoid is active.

A driving circuit is provided for units equipped with an optional head load solenoid. In order to exercise this option, HS jumper must be installed in the jumper block, which provides an output via an integrated circuit to J4, Pin 2.

3.3.1.2 Drive Motor Enable (N MOTOR ON)

Functional Description

When the Drive Motor Enable signal line logic level goes true (low), the disk drive's motor accelerates to its nominal speed of 300 rpm and stabilizes in less than 250 msec. When the logic level goes false (high), the disk drive's motor decelerates to a stop.

Test Point 13 (see Figure 3-4) is low (true) for the Motor On condition.

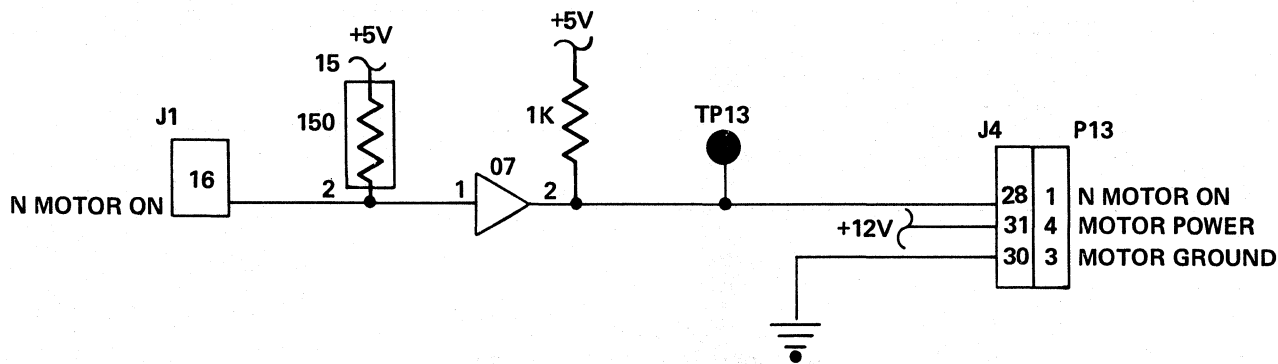

Figure 3-4
Drive Motor Enable Schematic Diagram

Circuit Description

The disk drive's Motor On signal comes in on Pin 16 and is buffered through an integrated circuit to the Servo PCBA.

3.3.1.3 Direction and Step Lines (Two Lines) (DIR) (N STEP)

Functional Description

When the disk drive is selected, a true (low) pulse with a time duration greater than 200 nsec on the Step line initiates the access motion. The direction of motion is determined by the logic state of the Direction line when a Step pulse is issued. The motion is toward the center of the disk drive if the Direction line is in the true (low) state when a Step pulse is issued. The direction of motion is away from the center of the disk drive if the Direction line is in the false (high) state when a Step pulse is issued. To ensure proper positioning, the direction line should be stable 100 usec (minimum) before the trailing edge of the corresponding Step pulse. The Direction line should remain stable until 100 usec after the trailing edge of the Step pulse. The access motion is initiated on the trailing edge of the Step pulse.

Test Point 8 (see Figure 3-5) is low (true) when the carriage is positioned at Track 00 and the stepper motor is at Phase 0 for the unipolar type of disk drive. See Figure 3-6 for the bipolar type of disk drive.

When stepping in or out, Test Point 12 (see Figure 3-5) is a high going pulse for each step of the carriage (see Table 3-4).

TABLE 3-4
STEPPER LOGIC TRUTH TABLE

Step In Toward Track 00					Step Out Toward The Upper Tracks						
Pin No.	Phase					Pin No.	Phase				
	0	3	2	1	0		0	1	2	3	0
4C-5	0	1	1	0	0	4C-5	0	0	1	1	0
4C-6	1	0	0	1	1	4C-6	1	1	0	0	1
4C-9	0	0	1	1	0	4C-9	0	1	1	0	0
4C-8	1	1	0	0	1	4C-8	1	0	0	1	1

Circuit Description (Unipolar Type)

The direction line comes in on Pin 18 of the interface connector. A high signal directs the step logic to step in toward Track 00. A low signal directs the stop logic to step out toward a higher numbered track.

The direction line sets the proper phase to the exclusive OR gates of IC 5D. This signal is also buffered by IC 3D to gate IC 4F to inhibit stepping inward when the disk drive is already at Track 00. This is done at Pin 4 of IC 4B.

The step pulses come in at Pin 20 of the interface connector. They are buffered by 2E and gated at IC 4B by the unit select, the Not Write signal, and by the inward step inhibit at the Track 00 signal. Then, the step pulses go to the C inputs of the two (2) flip flops at IC 4C. The direction of the step, hence the selection of the flip flop to be toggled, is done by the two (2) exclusive OR gates of IC 5D. These gates are controlled by the step direction line and by the state of the two (2) flip flop outputs.

IC 3E, Pins 5 and 6, resets the two (2) flip flops after a Power On.

The output of the two (2) flip flops drives the stepper motor through the drivers of IC 4D. The diodes are for voltage spike elimination.

Circuit Description (Bipolar Type)

The current is the same, except that the output of the two flip flops is buffered by the inverters through four additional drivers to the bipolar stepper motor. Then, the output is fed to the two sets of bipolar coils. The current is reversed through these stepper coils sequentially.

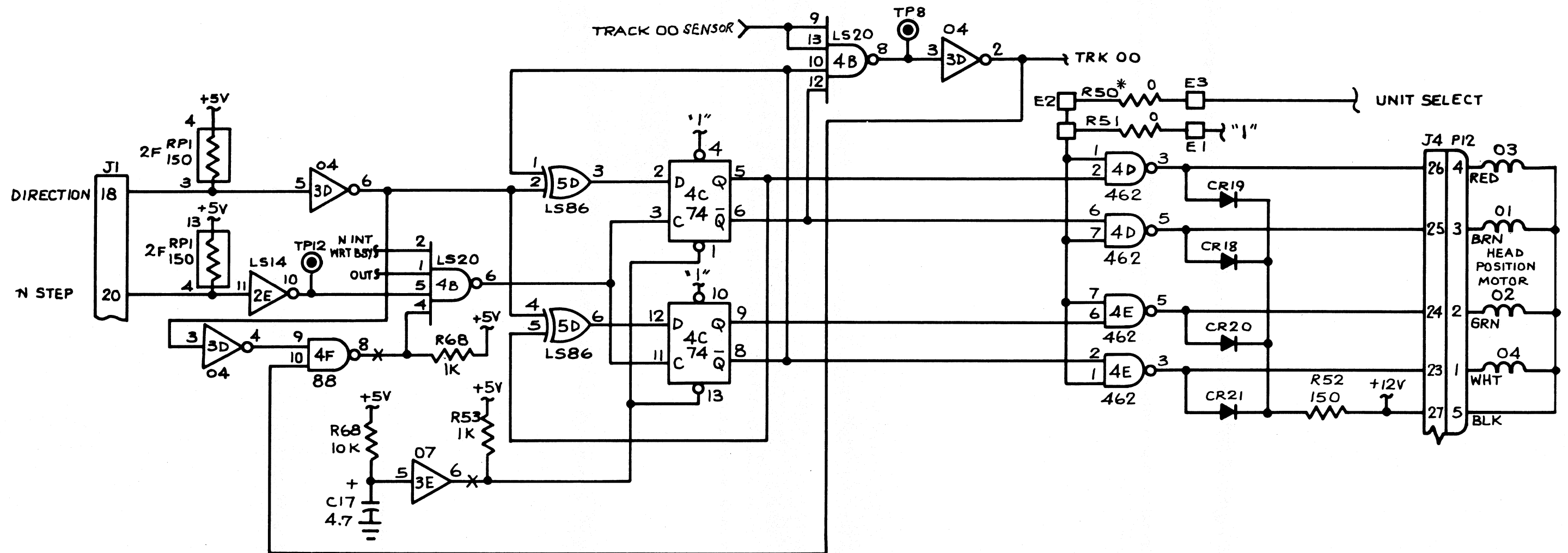

*Drive not usually shipped with R50 in place. R51 is in place.

Figure 3-5
Direction and Step Lines Schematic Diagram, Unipolar

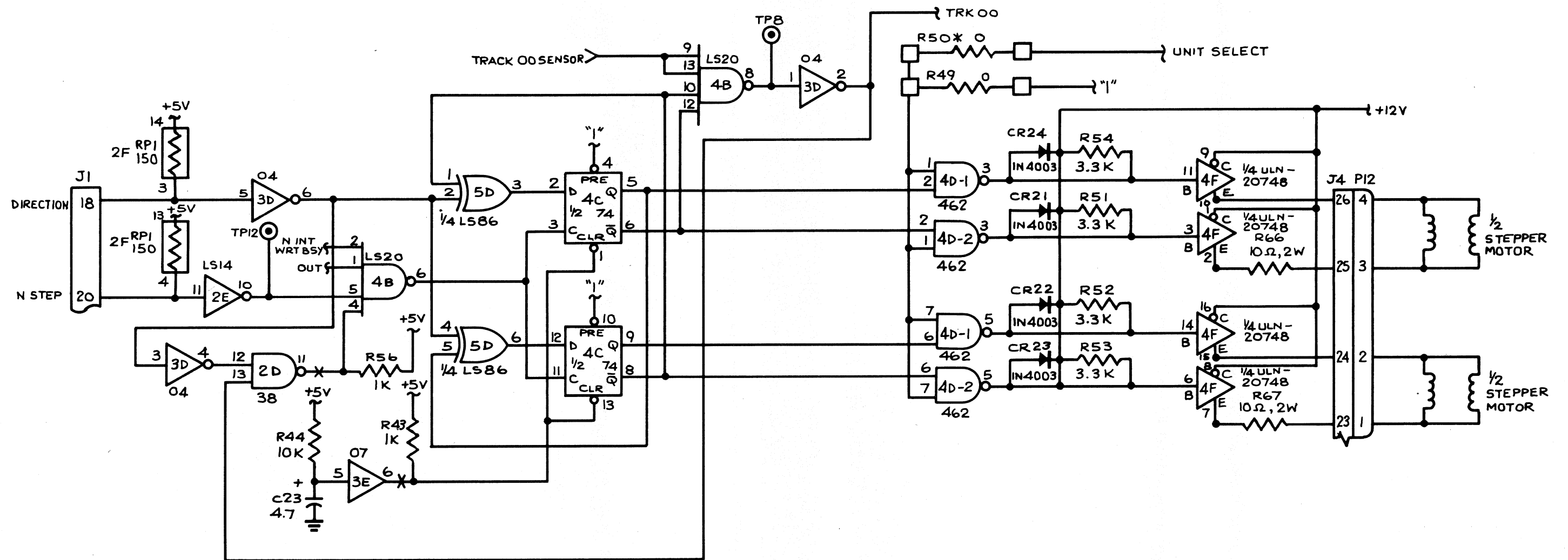

*Unit not usually shipped with R50 in place. R51 is in place.

Figure 3-6
Direction and Step Lines Schematic Diagram, Bipolar

The disk drive is shipped with R50 in place and with R51 not in place. If the resistor is moved to position R51, the power is only on to the stepper motor when the disk drive is selected. 3.8 watts of power are saved because power is not applied to the stepper motor unless the disk drive is selected.

3.3.1.4 Write Enable (N WRITE ENABLE)

Functional Description

When the Write Enable signal is true (low), the write electronics are prepared for writing data (read electronics disabled). This signal turns on the write current in the read/write head. Data is written under control of the Write Data input line. It is generally recommended that changes of state on the Write Enable line occur before the first Write Data pulse. However, the separation between the leading edge of Write Enable and the first significant Write Data pulse should not be less than four (4) usec and not greater than eight (8) usec. The same restrictions exist for the relationship between the least significant Write Data pulse and the termination of the Write Enable signal. When the Write Enable line is false (high), all write electronics are disabled.

When a write-protected diskette is installed in the disk drive, the write electronics are disabled, irrespective of the state of the Write Enable line. Stepping is also disabled by a true (low) Write Enable (see Section 3.3.1.3).

Tandon Corporation recommends that the controller wait one (1) msec after the N WRITE ENABLE goes false before any step pulses are sent to the disk drive.

Circuit Description

The Write Gate signal comes in on Pin 24 of the interface connector. It is buffered through IC 3D, and gated at IC 3B by the Write Protect and the Unit Select signals, becoming the N WRITE signal. The N WRITE signal goes to Pin 9 of IC 3C, which is configured as a delay. The output at Pin 12 goes high 390 usec after the N WRITE signal goes true.

The N WRITE signal also goes to IC 3C, Pin 1, which is configured as a one-shot delay. The output at Pin 13 goes low only 900 usec after it stops getting pulses at Pin 2 (the pulse from the write data circuit), and the N WRITE goes high or false.

The N ERASE signal is gated through IC 3B. It is true 390 usec after a write true and 900 usec after a write false. This signal enables the erase driver IC 2C. R58 controls the erase current.

Pin 4 of IC 3C is the Not Internal Write Busy signal. It enables Q5 through IC 3E, and gates twelve (12) volts to the selected head. This signal also disables the data output at IC 5E, Pin 11. The Not Internal Write Busy signal also enables the write flip flop IC 5C through IC 2E, Pin 12 and Pin 13.

Finally, the Not Internal Write Busy signal goes to driver 2B, Pin 10 and Pin 11, to disable the signal from the heads to the first-stage amplifier, using diodes CR11 and CR12 as gates.

3.3.1.5 Write Data (N WRITE DATA)

Functional Description

When the disk drive is selected, the write data line provides the bit-serial Write Data pulses that control the switching of the write current in the heads. The write electronics must be conditioned for writing by the Write Enable line (see Section 3.3.1.4).

For each high-to-low transition on the Write Data line, a flux change is produced at the head write gap. This causes a flux change to be stored on the disk drive (see Figure 3-7).

When the double-frequency type encoding technique is used (in which data and clock form the combined Write Data signal), it is recommended that the repetition of the high-to-low transitions, when writing all zeros, be equal to the nominal data rate ± 0.1 percent. The repetition rate of the high-to-low transitions, when writing all ones, should be equal to twice the nominal data rate $+ 0.1$ percent. The data transfer rate is 125,000 Bits Per Second (BPS) at single density; it is 250,000 BPS at double density.

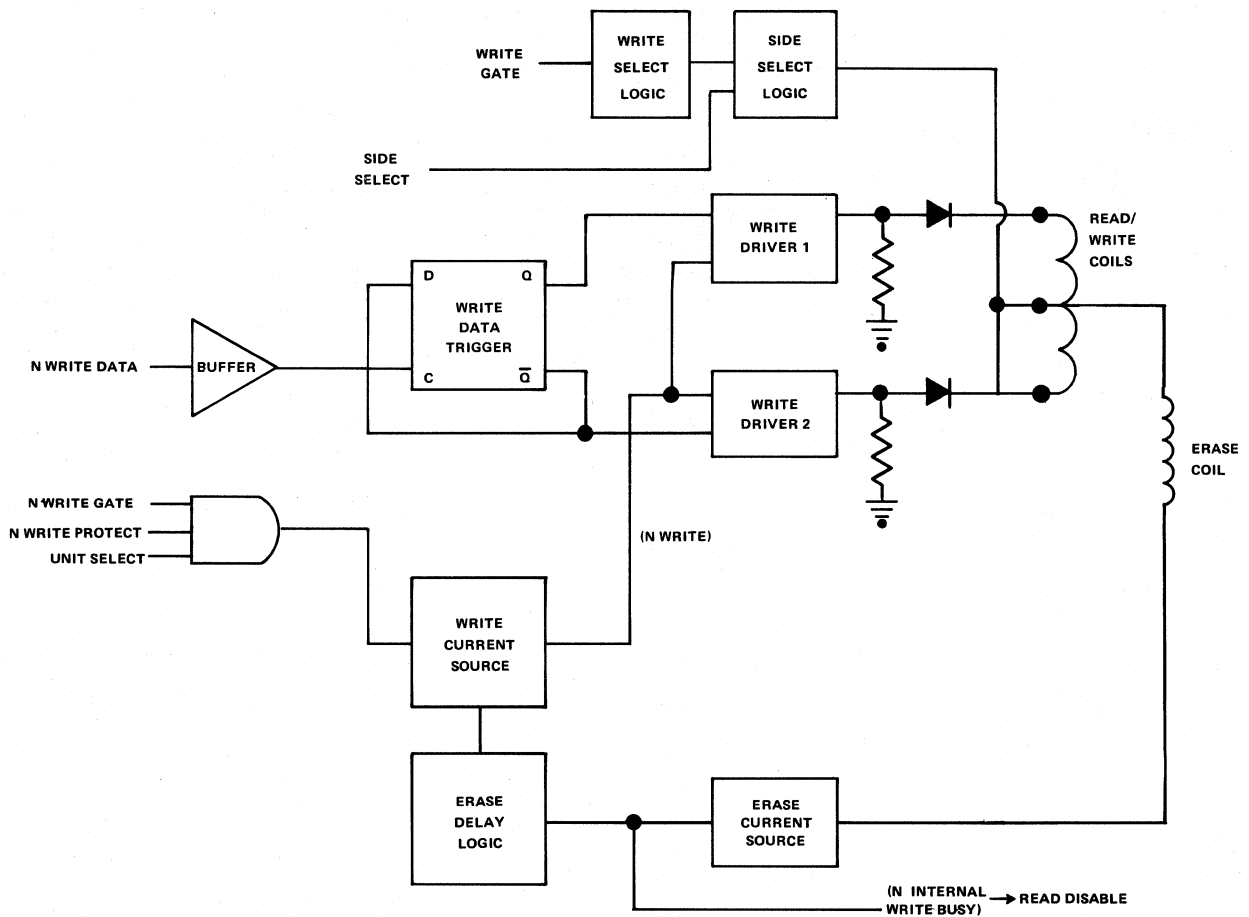

Figure 3-7
Write Data Circuit Block Diagram

Circuit Description

Data comes in on Pin 22 of the interface connector in pulse form. Subsequently it is buffered by IC 2E, then fed to a flip flop, IC 5C. The two outputs of the flip flop, through drive IC 2B, alternately turn on Q1 and Q2, which alternates the write current to the selected head. R31 controls the amount of write current (see Figure 3-8).

Q3 is activated by the write gate through IC 2B, IC 3B, and IC 3D (see Section 3.3.1.5).

Q4 is designed to allow write current to flow only after the five-volt line is high enough to forward-bias CR14, CR 15, and CR 16, which protects the disk from extraneous data being written when power is initially applied to the disk drive.

3.3.1.6 Side Select (N SIDE SELECT)

Functional Description

When the Side Select signal is low, Side 1 of the disk drive is selected for read/write operations. When this signal is high, Side 0 of the disk drive is selected (see Figure 3-9). The Side Select signal must be stable during an entire

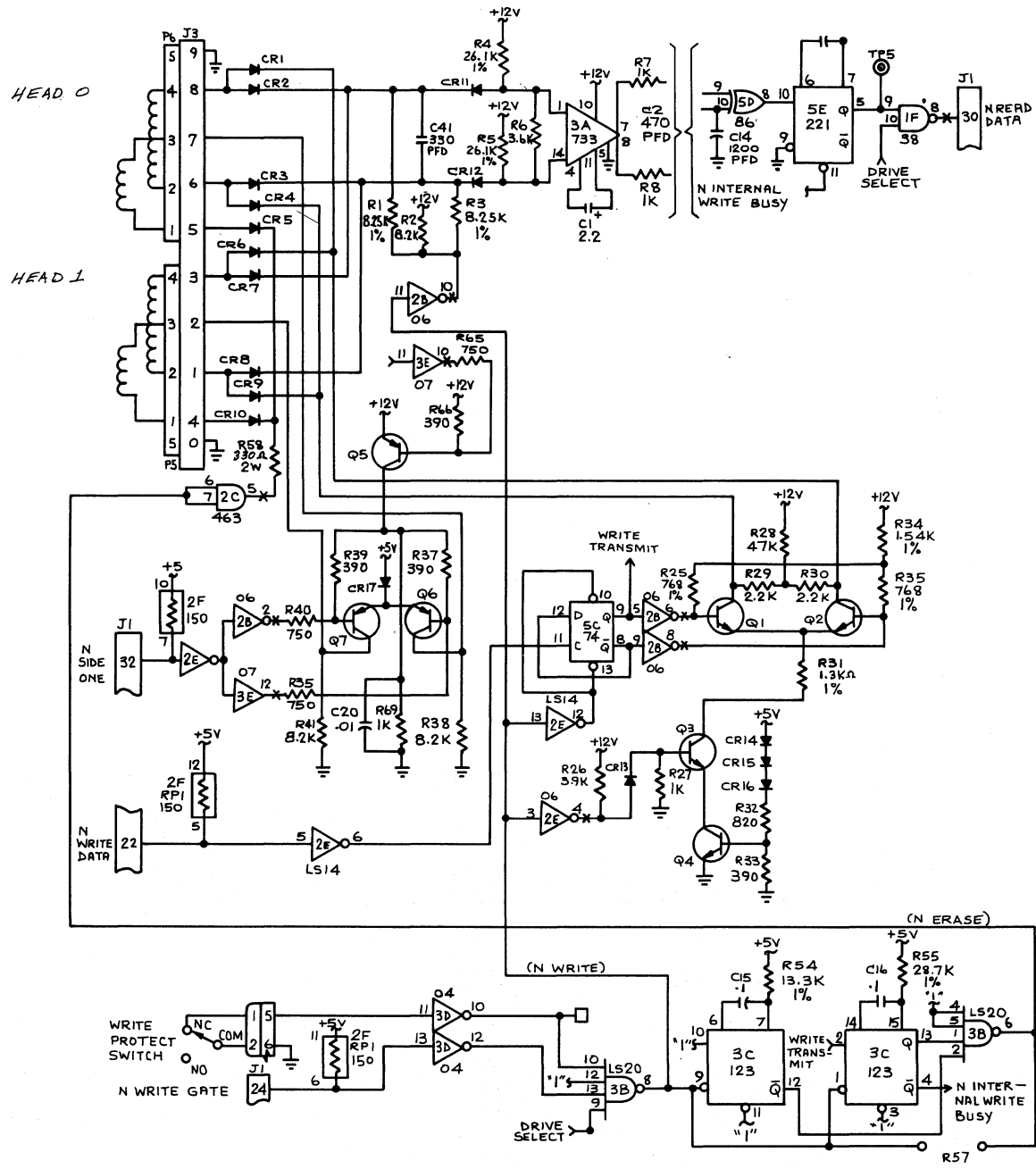

Figure 3-8
Write Data Schematic Diagram, Unipolar

read or write operation. This signal is best implemented in synchronization with the Device Select line signal (see Section 3.3.1.1).

Circuit Description

The Side Select signal comes in on Pin 32 of the interface connector. If this signal is high, Side 0 is selected. This signal is buffered through IC 2E (see Figure 3-9). From there, the Side Select signal is sent through IC 2B and IC 3E to Drive Q7 or Drive Q6. Drive Q7 sends current to the upper head (Head 1). Drive Q6 sends current to the lower head (Head 0).

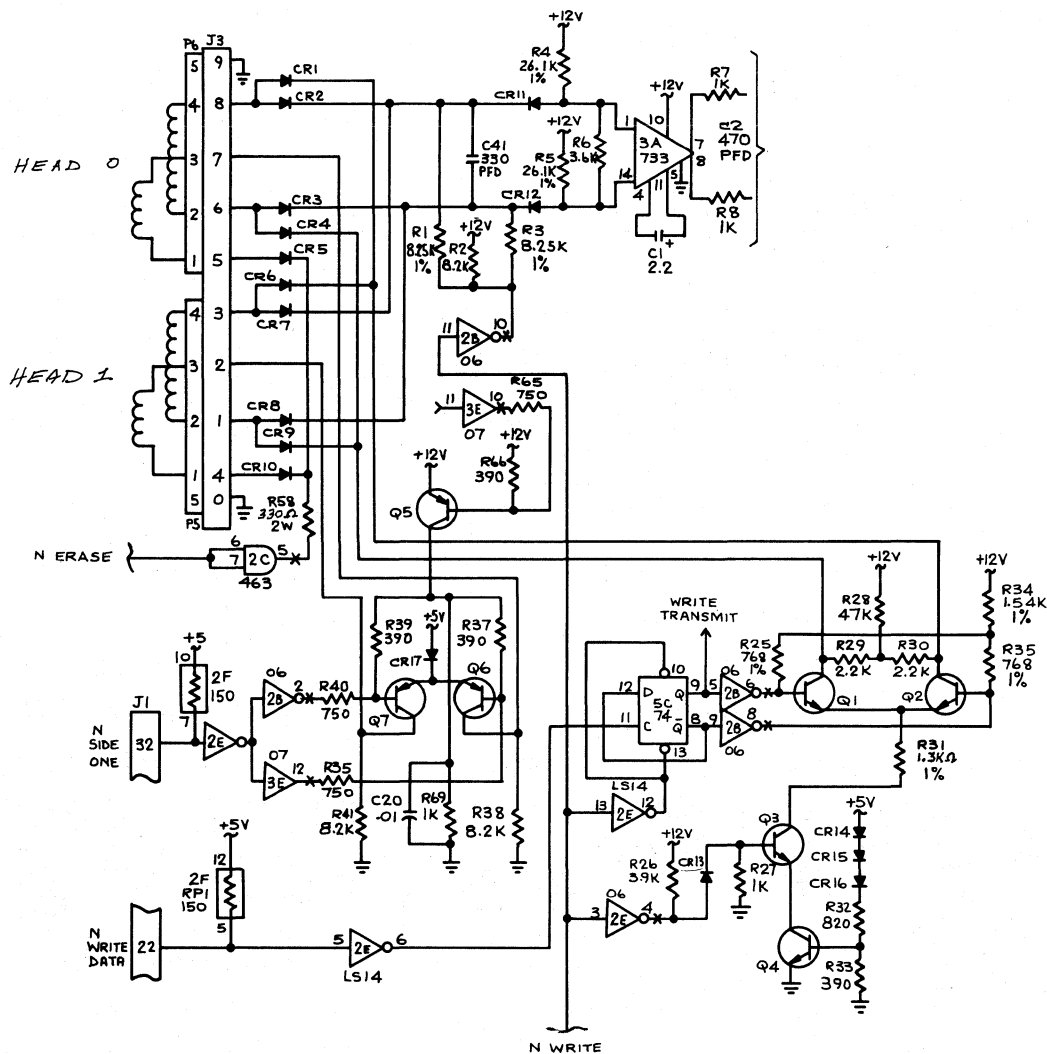

Figure 3-9
Side Select Schematic Diagram

3.3.2 Outputs

3.3.2.1 Index (N INDEX/SECTOR)

Functional Description

The Index signal is provided once each revolution (200 msec, nominal) to indicate the beginning of a track to the controller. The Index line remains in the true (low) state for the duration of the Index pulse. The duration of an Index pulse is nominally 4.0 msec.

The leading edge of an Index pulse must always be used to ensure diskette interchangeability between disk drives.

With a standard, soft-sectored diskette installed, Test Point 7 (see Figure 3-10 and Figure 3-11) is a high going pulse, nominally 4.5 msec in duration, every 200 msec.

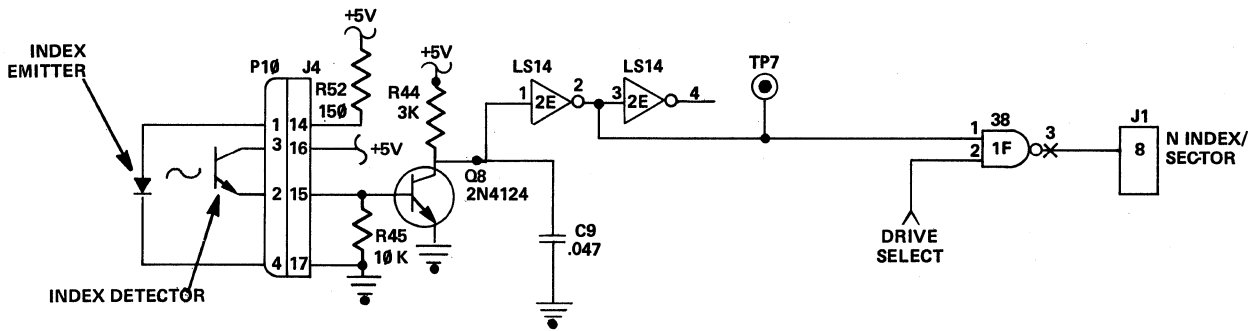

Figure 3-10
Index Schematic Diagram

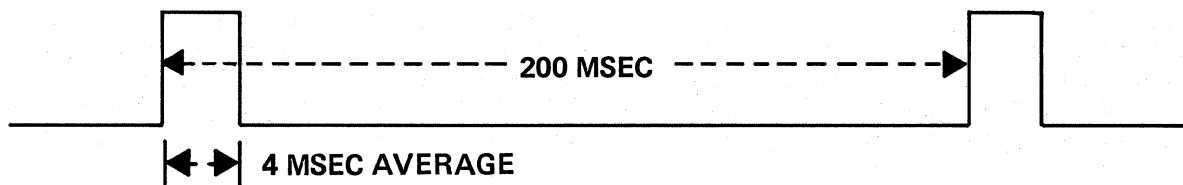

Figure 3-11
Waveform at Test Point 7 (Soft Sectored)

Circuit Description

The Index signal from the disk drive comes in on J4, Pin 15. The Index signal is derived from an infrared LED and a photo transistor detector. When the index hole in the disk drive allows the light to turn on the detector, Q8 is turned on, sending a signal through IC 2E to IC 1F to be gated by the Drive Select signal to produce a low output at Pin 8 of the interface connector.

3.3.2.2 Track 00 (N TRK 00)

Functional Description

When the disk drive is selected, the Track 00 Interface signal indicates, to the controller, that the read/write head is positioned at Track 00. The Track 00 signal remains true (low) until the head is moved away from Track 00. The Track 00 switch usually is deactivated between Track 1 and Track 2.

Test Point 8 (see Figure 3-12) is true (low) when the carriage is positioned at Track 00 and the Step Motor phase is correct.

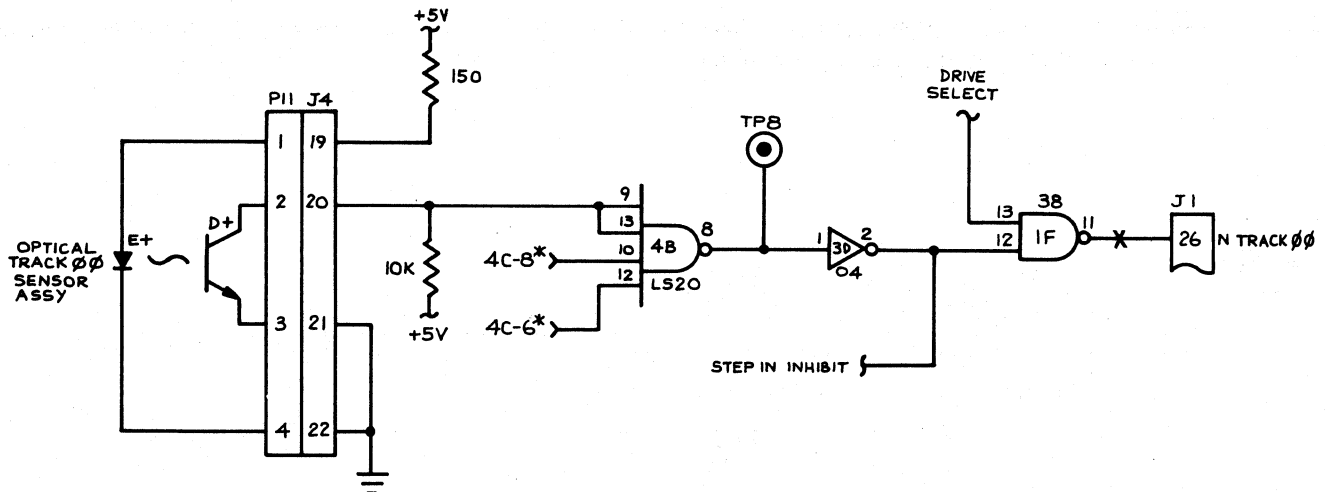

*4C-8 and 4C-6 are high on Phase 0 only.

Figure 3-12
Track 00 Schematic Diagram

Circuit Description

The Track 00 optical sensor is internal to the disk drive. Its signal comes in on Connector 11. The Track 00 sensor is activated between Track 1 and Track 2. The combination of the Track 00 sensor being activated and the proper stepping motor phase (Phase 0), produces all "high" signals at IC 4B, Pins 9, 10, 12, and 13. This signal subsequently is buffered through IC 3D, Pin 1 and Pin 2. IC 1F Pins 11, 12, and 13 gate the Track 00 output with the disk drive select output, to give a Track 00 output to the controller at Pin 26 of the interface connector.

3.3.2.3 Write Protect (N WRITE PROTECT)

Functional Description

When the disk drive is selected and the diskette is write protected, the Write Protect signal line logic level goes true (low). The write electronics are internally disabled when the diskette is write protected.

It is recommended that the Write data line be inactive whenever Write Enable is false, i.e., in a Read state, J1, Pin 24.

When the level on this line is false (high), the write electronics are enabled and the write operation can be performed. It is recommended that the controller not issue a Write command when the Write Protect signal is true (low).

When a write protected diskette is installed in the disk drive, Test Point 9 (see Figure 3-13) is high.

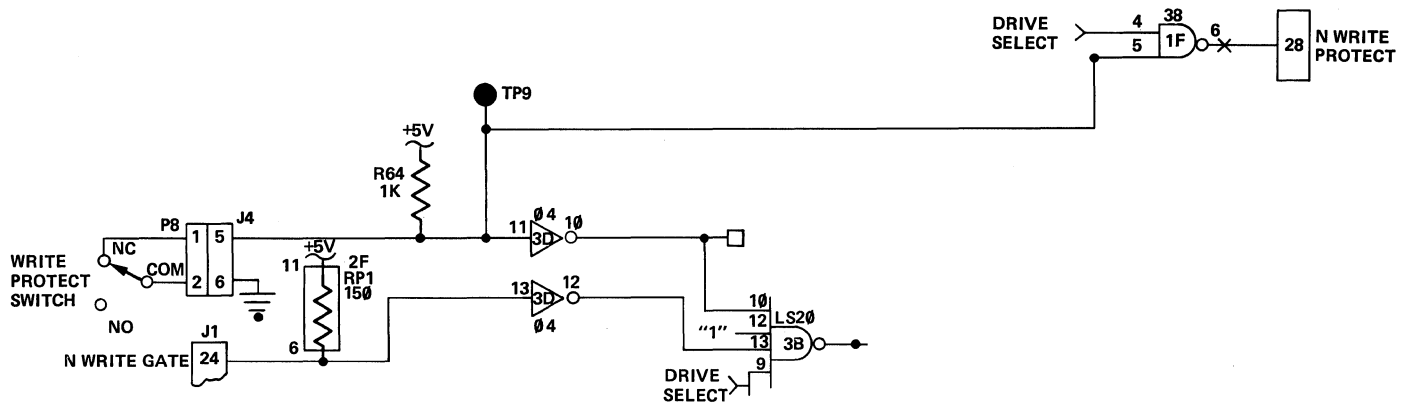

Figure 3-13
Write Protect Schematic Diagram

Circuit Description

The Write Protect signal comes in at Connector 8. Test Point 9 is held low when the switch is closed by a non-write protected diskette. The Write Protect output at Pin 28 of the interface is enabled at IC 1F, Pins 4, 5, and 6, by the Drive Select signal.

3.3.2.4 Read Data (N READ DATA)

Functional Description

The Read Data interface line transmits the readback data to the controller when the disk drive is selected. It provides a pulse for each flux transition recorded on the media. The Read Data output line goes true (low) for a duration of one (1) usec for each flux change recorded.

The leading edge of the Read Data output pulse represents the true positions for the flux transitions on the diskette surface.

Test Point 1 and Test Point 2 (see Figure 3-14) are provided to observe the differential output of the first stage of Read signal amplification. Test Point 3 and Test Point 4 are provided to observe the differential output of the second stage amplifier and differentiated Read signal. Test Point 5 is the output of the single shot used in the Read section, nominally 1.0 usec for each flux transition detected. Test Point 10 is signal ground.

Circuit Description

The read signal comes from the selected head on the disk drive. It is gated to the first amplifier (IC 3A) by the N WRITE signal to IC 2B, Pin 11 and Pin 10, which forward-biases diodes CR11 and CR12. Then the Read signal passes through C2, L1, L2, C3, C4, and C5, which is a bandpass filter. The Read signal is then at the input IC 4A, the differentiator, which is also Test Point 1 and Test Point 2.

The output of IC 4A goes through DC blocking capacitors C7 and C8 to the crossover detector, IC 5B, which digitizes the AC signal. This puts the signal into a standard TTL format. IC's 5D, 5E, and 5C comprise a comparator circuit. Any pulses that occur outside of the normal duty cycle of IC 5B are eliminated. IC 5D is an edge detector. IC 5E acts as a one-shot. IC 5C is the actual comparator.

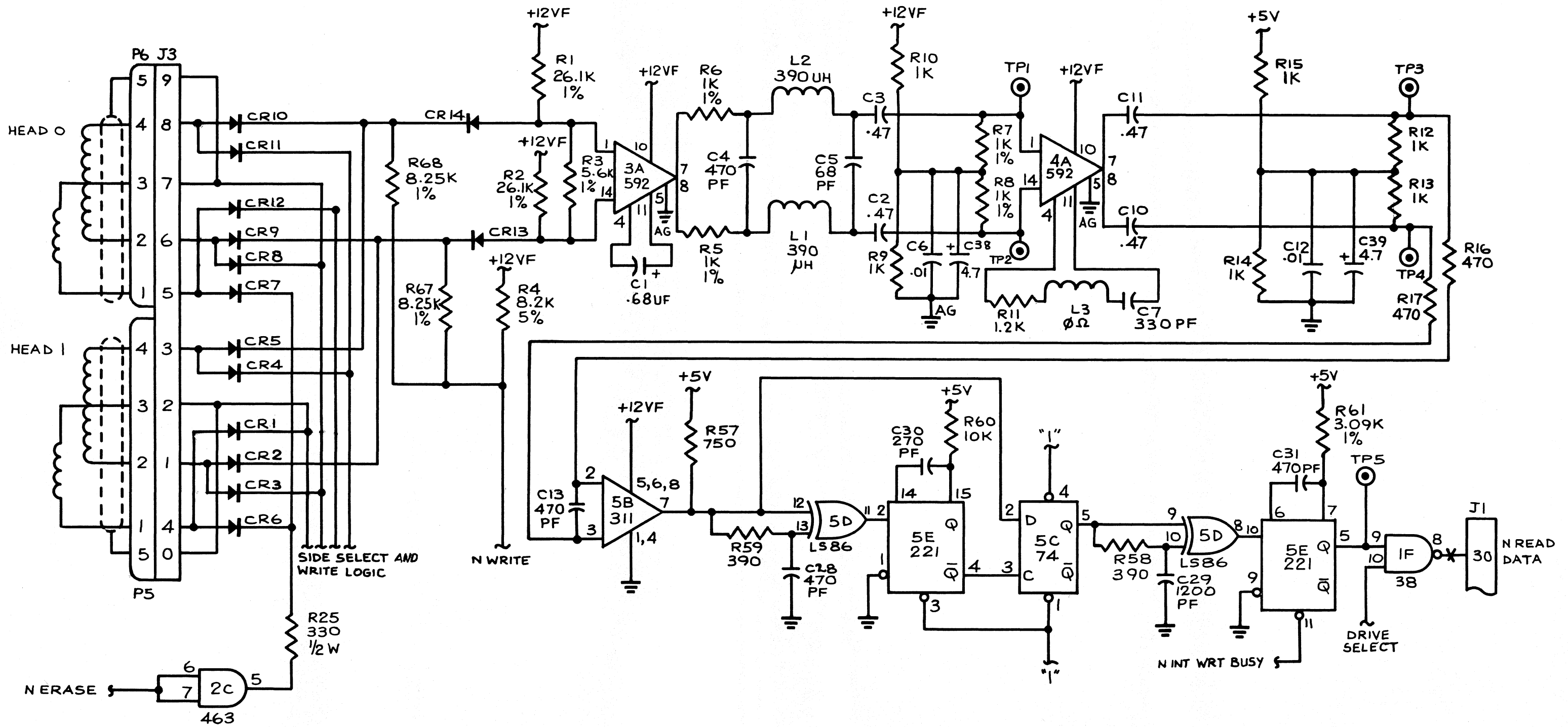

Figure 3-14
Read Data Schematic Diagram, Bipolar

The Read signal is presented to IC 5D, which is another edge detector, and then goes to IC 5E, where the pulses are shaped to 1 usec. This output is gated at IC 1F with the Unit Select signal to produce a digital output at Pin 30 of the interface connector (see Figure 3-15).

NOTE

IC 5E, the final one shot, is enabled only when the disk drive is in a Read state (Pin 11).

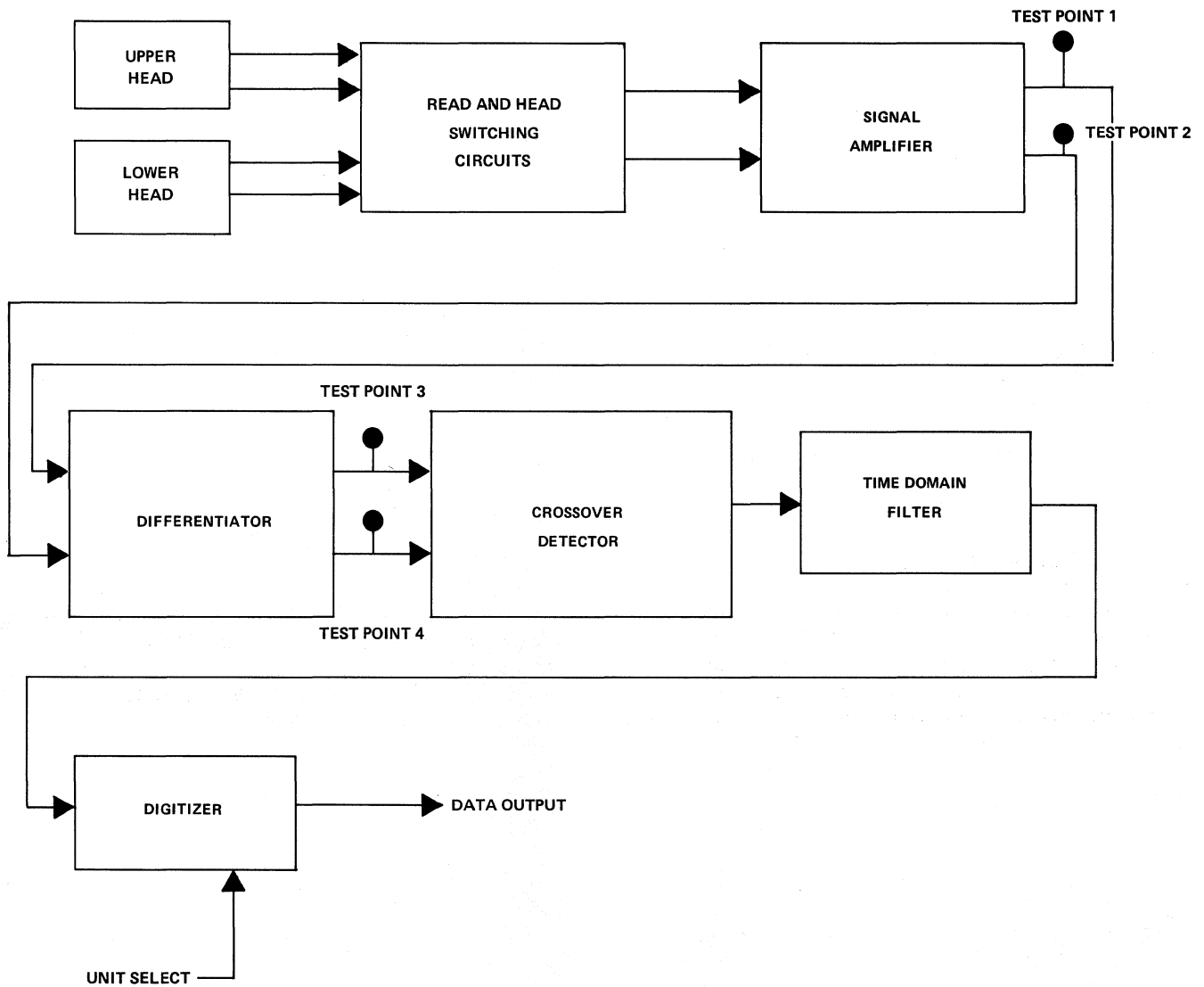

Figure 3-15
Read Circuit Block Diagram

3.4 PHYSICAL DESCRIPTION OF THE SERVO PCBA

The Servo PCBA is approximately 127 mm (5.0 inches) long by 38 mm (1.5 inches) wide. Figure 3-16 illustrates the placement of connectors and the motor speed control.

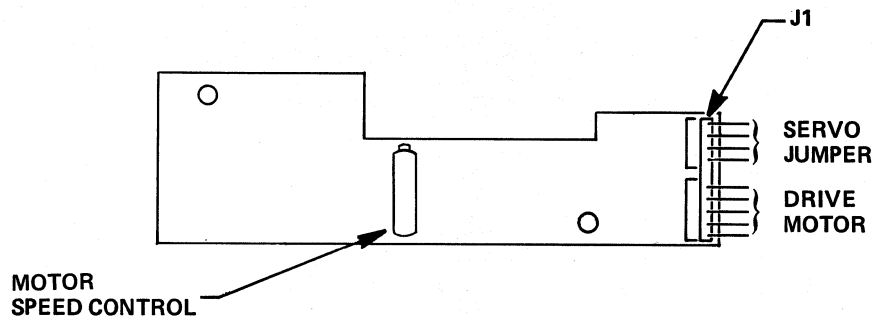

Figure 3-16
Servo PCBA

3.4.1 Input Control Lines

Functional Description

When the logic board receives a true (low) Motor On signal, a true (low) signal is sent to the servo board (N MOTOR ON) (see Figure 3-17). This signal turns on the regulator (Q1), and the motor's speed accelerates to 300 rpm ($\pm 1.5\%$).

R4 is adjusted for a motor speed of 300 rpm.

The motor supplies a 12-volt AC tachometer signal to the servo board for regulation control.

Circuit Description

The Motor On signal comes in at Pin 7 of the servo board (see Section 3.3.1.2). This turns off Q2, allowing the signal to be sent to the base of Q1. The signal to the base of Q1 is the output of the regulator IC Pin 8. This is controlled by the tach input at Pin 1 and Pin 2 of the servo board. The tach signal is an AC signal of twelve (12) volts. The other input to the regulator is from the voltage divider R3, R4, and R5. This voltage is adjustable by R4, a potentiometer, to produce the proper amount of current through Q1 to the drive motor.

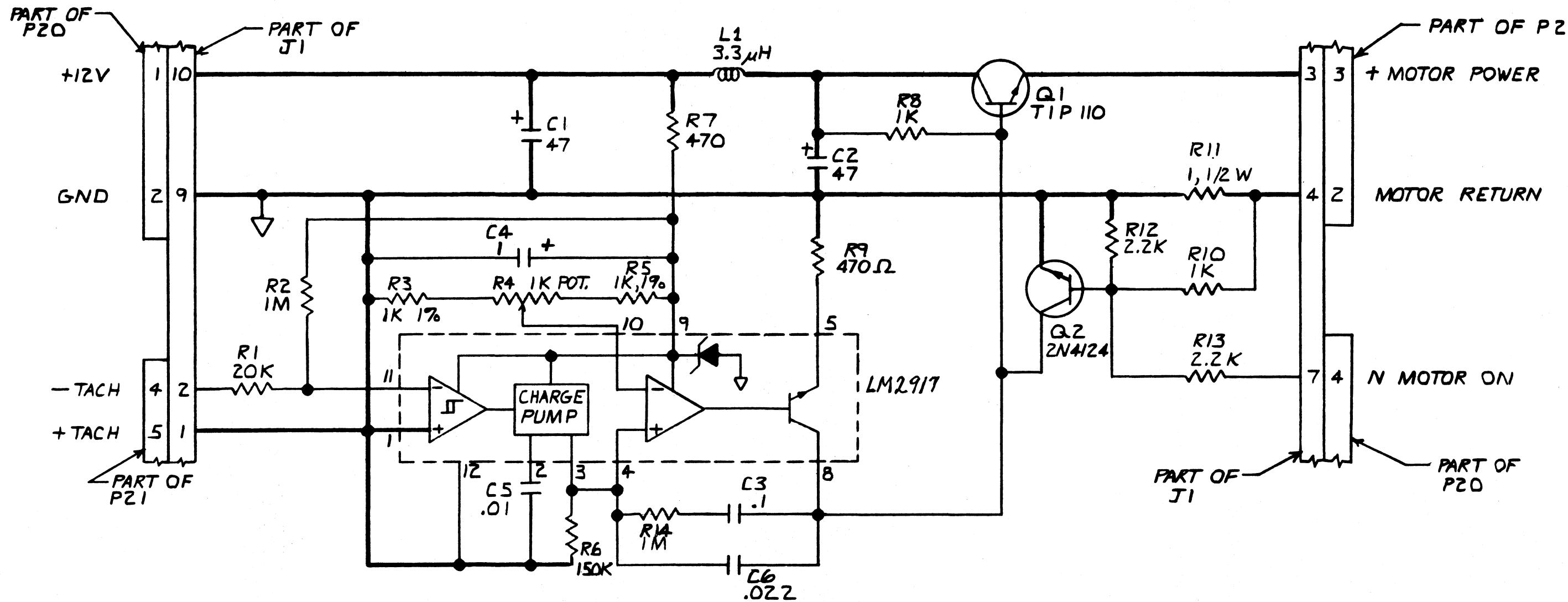

- NOTES: UNLESS OTHERWISE SPECIFIED**
1. RESISTORS ARE IN OHMS, $\pm 5\%$, 1/4 W.
 2. 1% RESISTORS ARE 1/8 W.
 3. CAPACITORS ARE IN μF , $\pm 20\%$, 35V.

Figure 3-17
Servo Board Schematic Diagram

SECTION IV TROUBLESHOOTING GUIDE

4. INTRODUCTION

This section is presented in for form of a table. Each section contains four major parts:

1. The section number.
2. A statement of the presenting condition.
3. A list of the possible causes of the condition.
4. The recommended action to be taken.

<u>SECTION</u>	<u>CONDITION</u>	<u>POSSIBLE CAUSE</u>	<u>RECOMMENDED ACTION</u>
4.1	Not ready and/or no index.	Diskette not inserted.	Insert diskette.
		Door not closed.	Close door.
		Unit not selected.	Verify unit select and jumper configuration.
		Drive motor not turning.	Verify interface drive motor on. Check Connectors P13, P20, and P21. Verify drive belt installed. Replace Servo PCBA. Replace Drive Motor Assembly.
		Index sensor not connected.	Check P10.
		Index sensor defective.	Replace index sensor.
4.2	Will not seek or restore.	Interface not enabled.	Verify interface direction, step, and select signals.
		Step motor disconnected.	Check Connector P12.
		Defective step logic,	Replace Logic PCBA.
		Defective step motor.	Replace Module Assembly.
4.3	Will not write.	Interface not enabled.	Verify write enable, select, and write data interface lines.
		Heads or write protect switch not connected.	Check Connectors P5, P6, and P8.
		Write protect switch misadjusted	Check write protect switch operation.
	Will not write.	Defective write logic.	Replace Logic PCBA.
		Defective heads.	Replace Module Assembly.

<u>SECTION</u>	<u>CONDITION</u>	<u>POSSIBLE CAUSE</u>	<u>RECOMMENDED ACTION</u>
4.4	Will not read.	Interface incorrect.	Verify select is true and write enable is false.
		Alignment off.	Verify C. E. lobes, index burst, and Track 00 switch adjustment.
		Defective read electronics.	Replace Logic PCBA.
		Defective heads.	Replace Module Assembly.
4.5	Front panel LED inoperative.	Interface not enabled.	Verify interface selecty and jumper configuration.
		LED not connected.	Check P9.
		LED defective.	Replace Front Panel LED Assembly.
		LED driver defective.	Replace Logic PCBA.
4.6	No Track 00 sensor indication.	Defective seek.	See Section 4.2.
		Track 00 sensor not connected.	Check P11.
		Defective logic.	Replace Logic PCBA.
		Defective Track 00 sensor.	Replace Track 00 Sensor Assembly.

SECTION V REPLACEMENT PROCEDURES

5. INTRODUCTION

This section contains the replacement procedures for the TM100 family of disk drives' parts and assemblies:

1. Drive Belt
2. Logic PCBA
3. Servo PCBA
4. Cone Lever Assembly
5. Cone Kit
6. Activity LED Assembly
7. Front Panel
8. Guide Rail
9. Index Assembly
10. Drive Motor Assembly
11. Track 00 Sensor Assembly
12. Write Protect Switch Assembly
13. Upper Arm Assembly
14. Module Assembly
15. Spindle Assembly
16. Latch Plate Assembly

5.1 DRIVE BELT

5.1.1 Remove the old drive belt from the pulleys (see Figure 5-1).

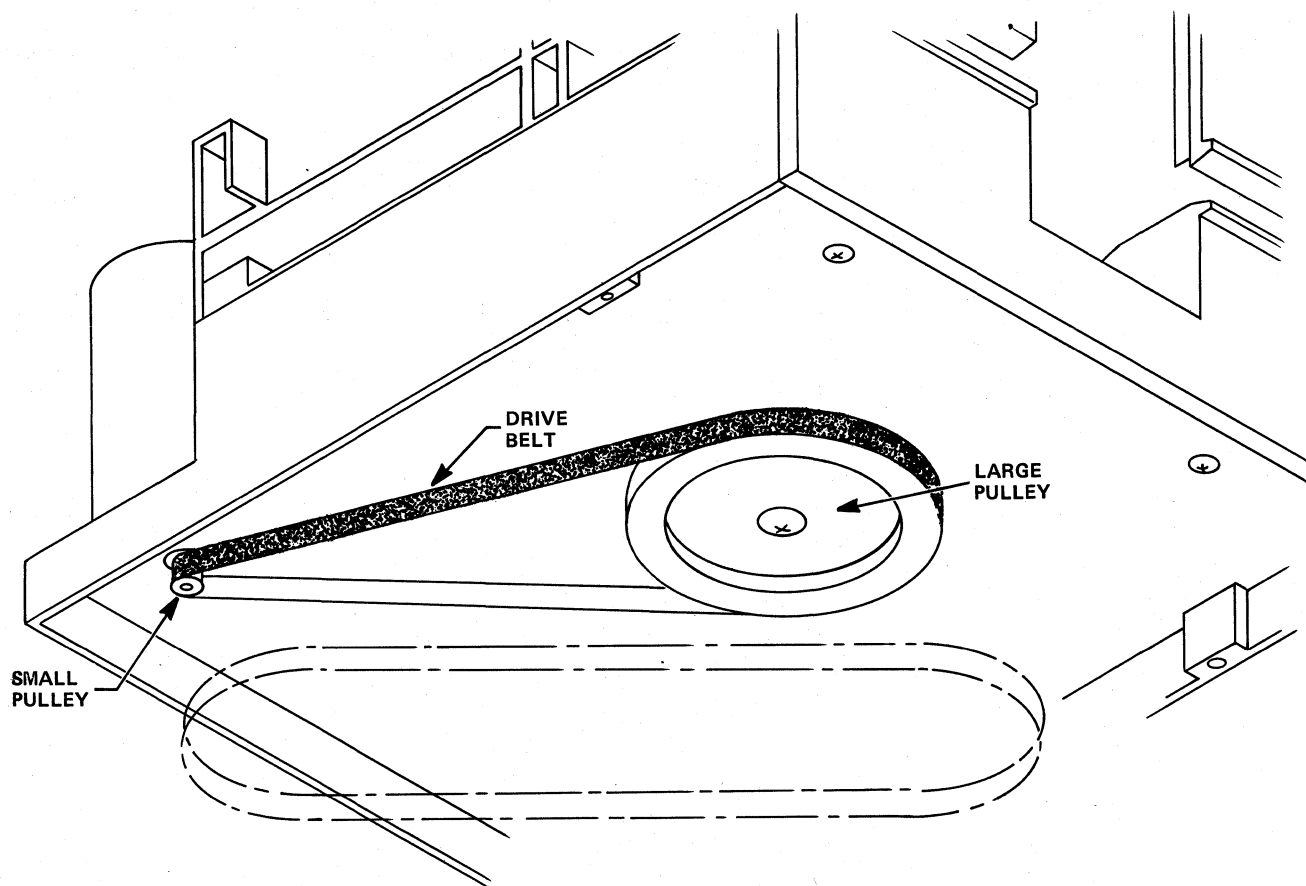

Figure 5-1
Drive Belt and Pulleys

5.1.2 Taking care not to stretch the new drive belt, install it with the dark, shiny side facing the pulleys (see Figure 5-1).

NOTE

Put the drive belt on the small pulley first, then on the large one.

5.2 LOGIC PRINTED CIRCUIT BOARD ASSEMBLY (PCBA)

5.2.1 Unplug the eight (8) connectors on the Logic PCBA (see Figure 5-2).

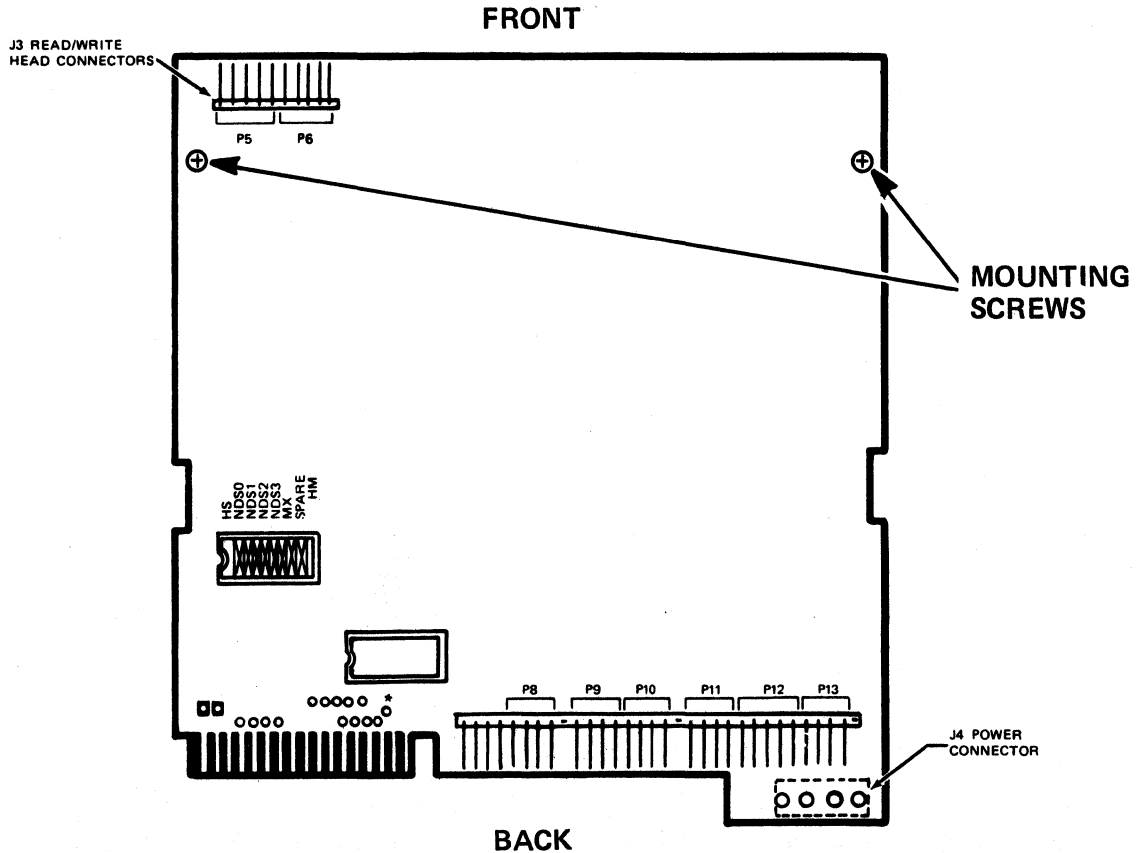

Figure 5-2
Logic PCBA Connectors and Mounting Screws

- 5.2.2 With a Phillips screwdriver, remove the two (2) mounting screws that attach the Logic PCBA to the chassis (see Figure 5-2).
- 5.2.3 Slide the right side of the Logic PCBA toward the back of the disk drive about one-half (1/2) inch.
- 5.2.4 Lift the Logic PCBA off of the disk drive.
- 5.2.5 Place the new Logic PCBA on the disk drive, reversing the procedure in Sections 5.2.1 through 5.2.3.
- 5.2.6 With a Phillips screwdriver, install the two (2) screws that attach the Logic PCBA to the rails.
- 5.2.7 Plug in all connectors, ensuring that they are in their proper slots (see Figure 5-2).

5.3 SERVO PRINTED CIRCUIT BOARD ASSEMBLY (PCBA)

5.3.1 Detach connectors P20 and P21 from the Servo PCBA (see Figure 5-3), located at the back of the disk drive.

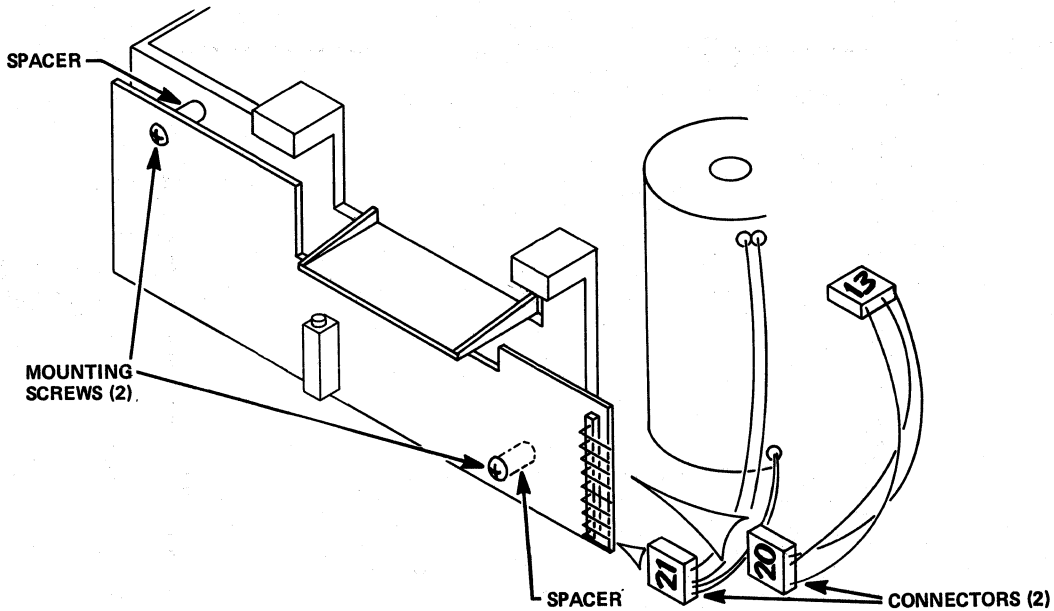

Figure 5-3
Servo PCBA Connectors, Mounting Screws, and Spacers

5.3.2 Using a Phillips screwdriver, remove the two (2) mounting screws and the two (2) spacers that attach the Servo PCBA to the chassis.

NOTE

Be sure to save the spacers and the mounting screws.

5.3.3 Remove the Servo PCBA from the chassis.

5.3.4 Stand up the disk drive on its front panel.

NOTE

Be careful not to scratch the front panel.

5.3.5 Place the two (2) spacers on top of the two (2) holes in the chassis.

5.3.6 Place the new Servo PCBA on top of the two (2) spacers.

NOTE

Be sure to align the holes in the Servo PCBA with the holes in the spacers.

- 5.3.7 Using a Phillips screwdriver, attach the Servo PCBA to the chassis with the two (2) mounting screws.

NOTE

If a nylon screw is used, ensure that it is installed at the same location.

- 5.3.8 Plug Connectors P20 and P21 into their proper slots on the Servo PCBA — P20 on the top and P21 on the bottom — see Figure 5-3.
- 5.3.9 Check the drive motor speed (see Section 2.1.1).
- 5.3.10 Check the Instantaneous Speed Variation (ISV) (see Section 2.1.2).

5.4 CONE LEVER ASSEMBLY

5.4.1 Remove the Logic PCBA from the disk drive (see Section 5.2).

5.4.2 Open the front door, located in the front panel of the disk drive.

NOTE

The Cone Lever Assembly automatically lifts up.

5.4.3 Cut the tie wrap that attaches the top index cables to the Cone Lever Assembly.

5.4.4 With a Phillips screwdriver, remove the mounting screw that attaches the index emitter holder to the Cone Lever Assembly (see Figure 5-4).

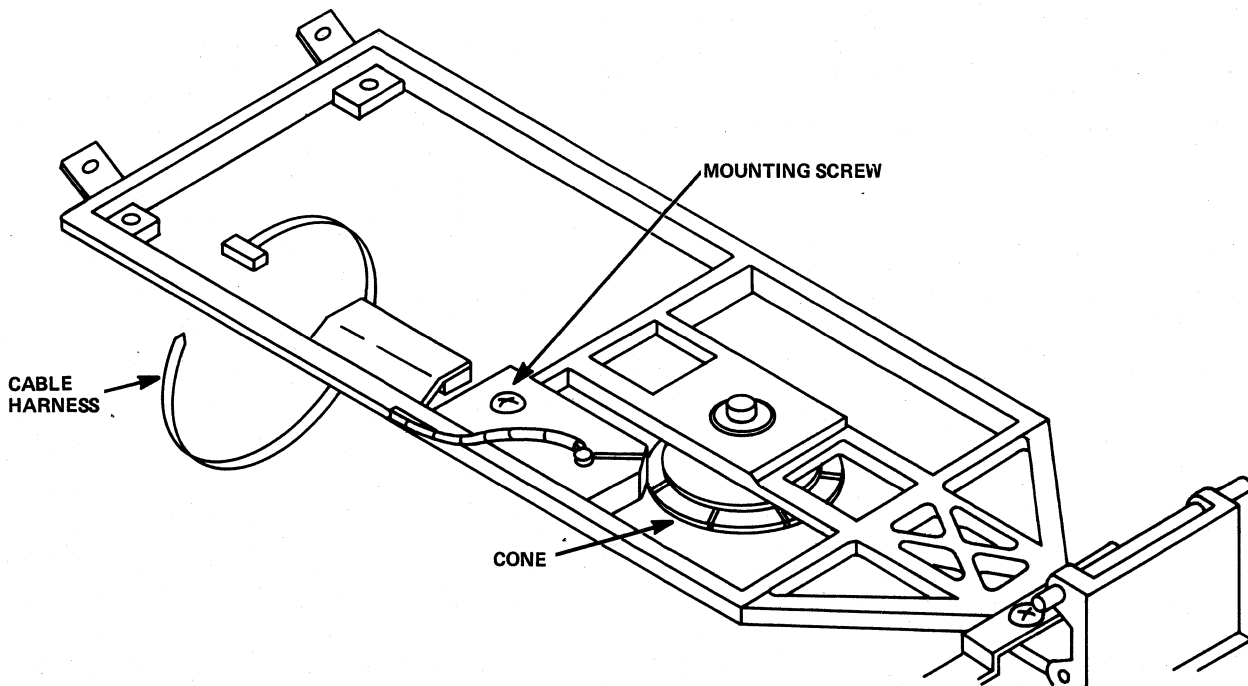

Figure 5-4
Cone Lever Assembly Harnessing and Mounting

5.4.5 Unloop the two (2) head cables from the right rail in two (2) places.

5.4.6 At the rear of the Cone Lever Assembly, cut the two (2) cable harnesses that hold the stepper motor cables in place (see Figure 5-5).

5.4.7 With a Phillips screwdriver, remove the two (2) mounting screws that attach the Cone Lever Assembly to the chassis.

5.4.8 Gently slide the head carriage to the front of the disk drive.

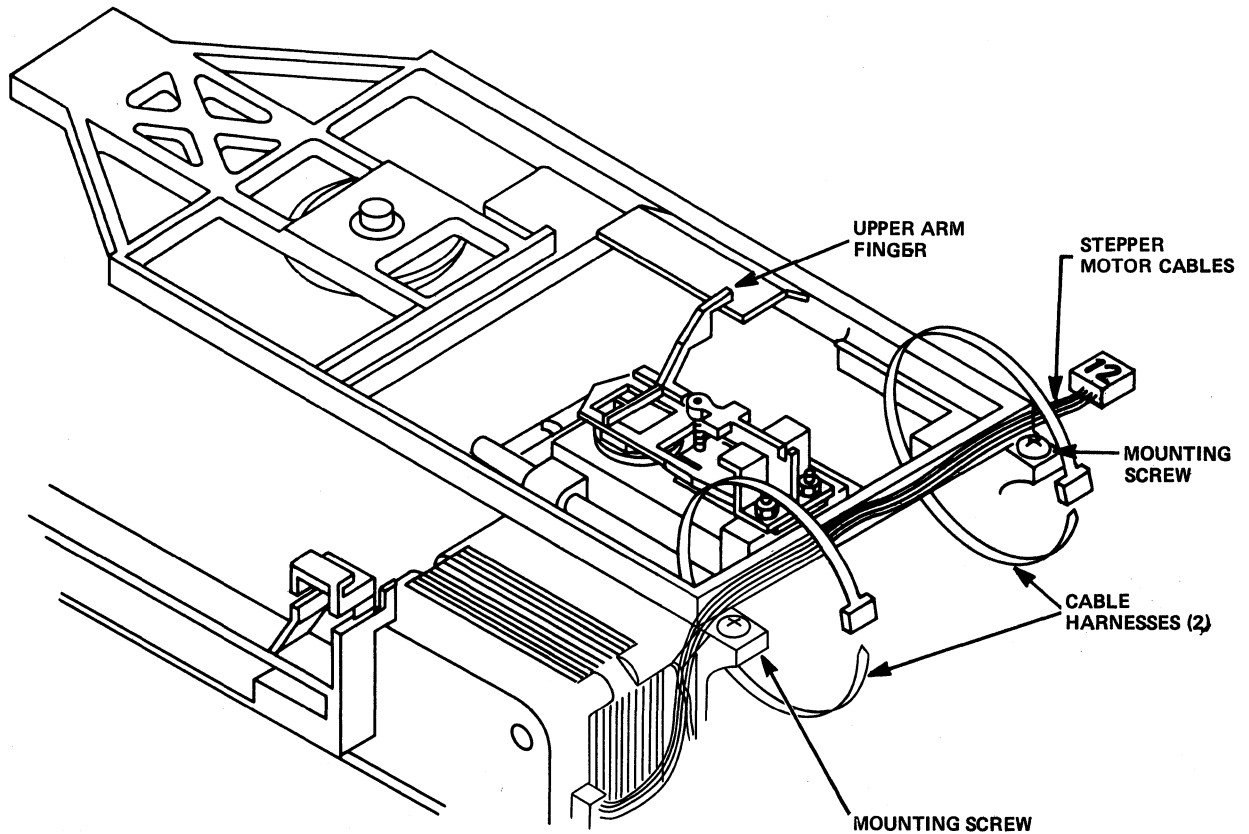

Figure 5-5
Cone Lever Assembly Harnessing, Mounting, and Stepper Motor Cables

- 5.4.9 Slide the Cone Lever Assembly rearward to release the upper arm finger (see Figure 5-5).
- 5.4.10 Remove the Cone Lever Assembly by lifting it up and toward the rear of the disk drive, and sliding the front door out of its tracks.
- 5.4.11 Holding the new Cone Lever Assembly, put the front door into its tracks, and move it as far as it will go toward the front of the disk drive. Then, carefully lower the cone lever, lifting the upper arm finger over the cone lever.
- 5.4.12 With a Phillips screwdriver, install but do not tighten the two (2) mounting screws that attach the rear of the Cone Lever Assembly to the chassis.
- 5.4.13 Re-loop the two (2) head cables over the right rail in two (2) places.
- 5.4.14 Using a Phillips screwdriver, install the mounting screw that attaches the index emitter holder to the Cone Lever Assembly.
- 5.4.15 Harness the top index emitter cables to the Cone Lever Assembly (see Figure 5-6).

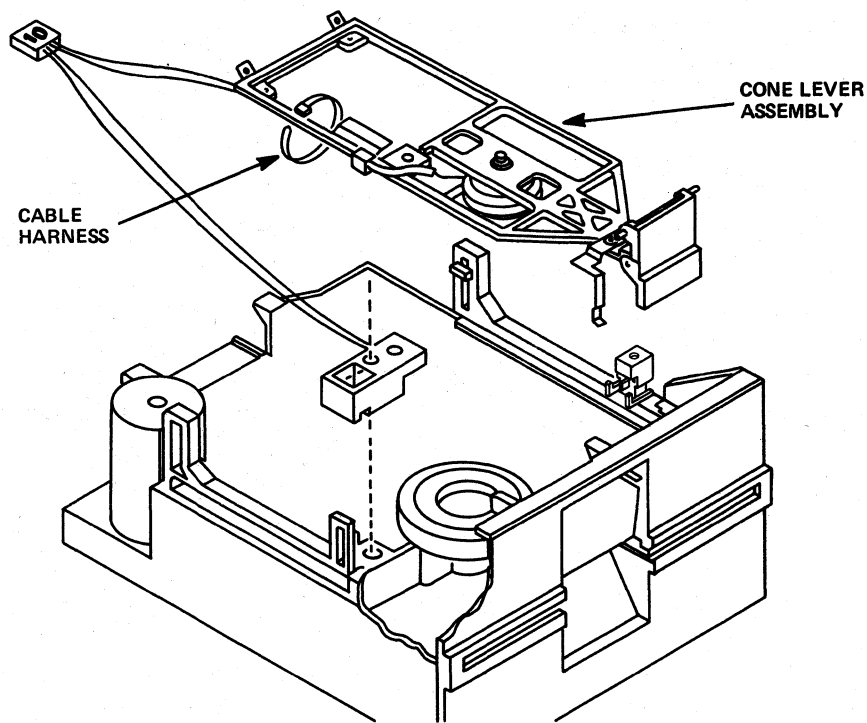

Figure 5-6
Cone Lever Assembly Cable Harness

- 5.4.16 Gather together and harness the stepper motor cables in two (2) places at the rear of the Cone Lever Assembly (see Figure 5-5).
- 5.4.17 Close the front door of the disk drive to engage the cone and the hub.
- 5.4.18 Ensure that the cone is centered in the lever (shaft) hole.
- 5.4.19 With a Phillips screwdriver, tighten the two (2) mounting screws that attach the Cone Lever Assembly to the chassis.
- 5.4.20 Check to ensure there is a $0.010'' \pm 0.001''$ clearance between the E-ring and the washer when the cone is clamped — the result of the front door being closed.
- 5.4.21
If necessary, adjust the clearance by adding or deleting a washer located under the E-ring (see Figure 5-7).

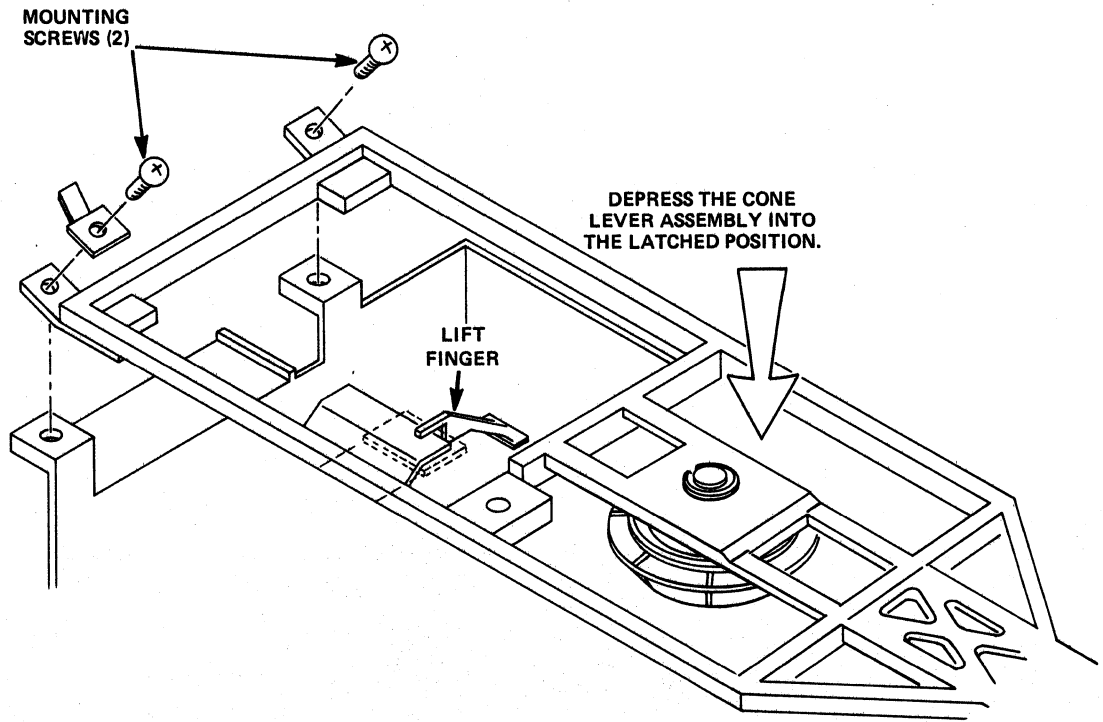

Figure 5-7
Cone Shaft and E-Ring

5.4.22 Reinstall the Logic PCBA (see Section 5.2).

5.5 CONE KIT

5.5.1 Remove the Logic PCBA (see Section 5.2).

5.5.2 Remove the Cone Lever Assembly (see Section 5.4) (see Figure 5-8).

5.5.3 Remove the E-ring that holds the cone shaft on.

NOTE

The cone's parts are now loose from the cone lever.

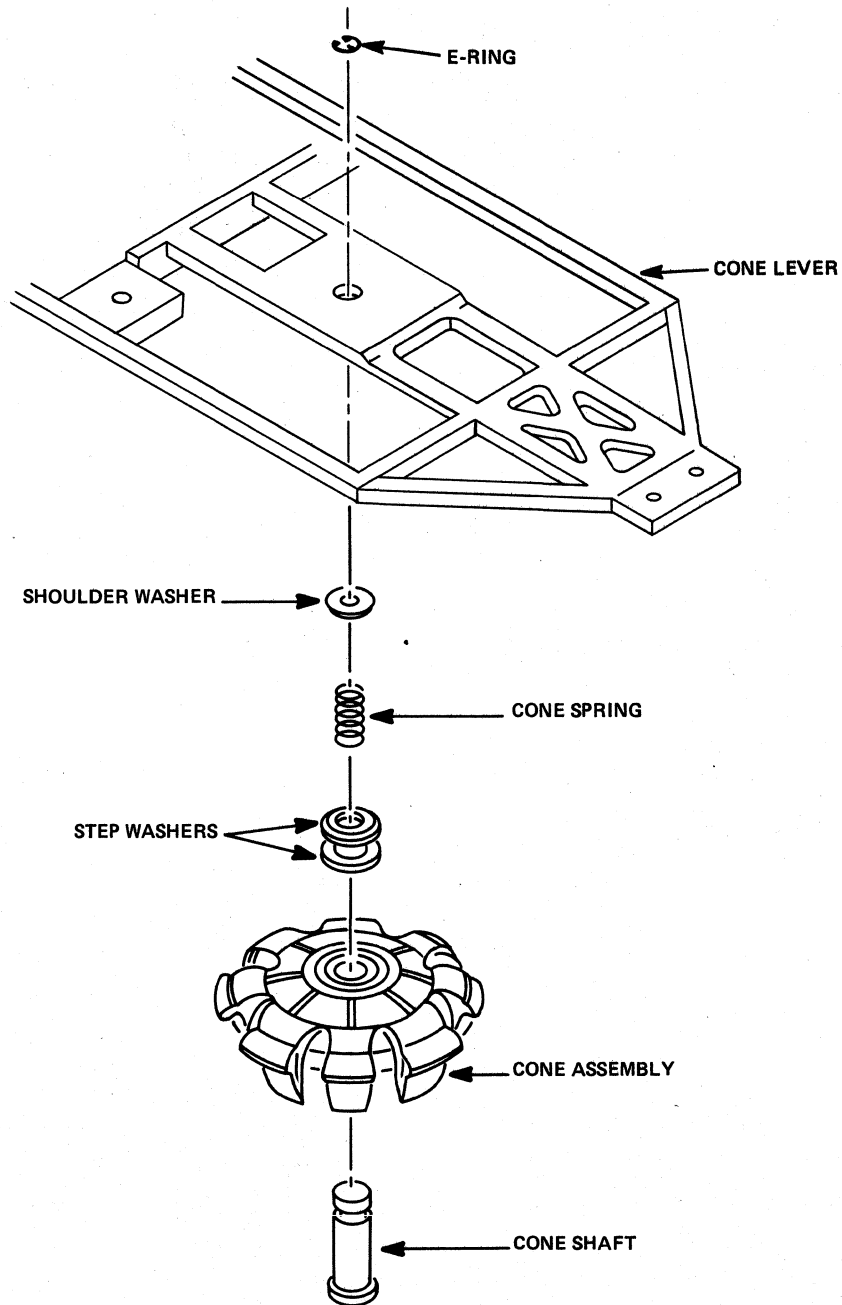

Figure 5-8
Cone's Component Parts

- 5.5.4 Put the cone shaft through the cone.
- 5.5.5 Slip on the step washer, the cone spring, and the shoulder washer.
- 5.5.6 Compress the spring, and put the cone shaft through the hole in the Cone Lever Assembly.
- 5.5.7 Install the E-ring in order to retain the Cone Lever Assembly (see Figure 5-8).
- 5.5.8 Reinstall the Cone Lever Assembly (see Section 5.4.12).
- 5.5.9 Make the required checks (see Section 5.4.21).
- 5.5.10 Reinstall the Logic PCBA (see Section 5.2).

5.6 ACTIVITY LIGHT EMITTING DIODE (LED) ASSEMBLY

5.6.1 Remove the Logic PCBA (see Section 5.2).

5.6.2 Cut the two (2) cable harnesses that attach the Activity LED Assembly and the Write Protect Switch Assembly to the chassis in front of the drive motor and to the bundle of wires in back of the drive motor (see Figure 5-9).

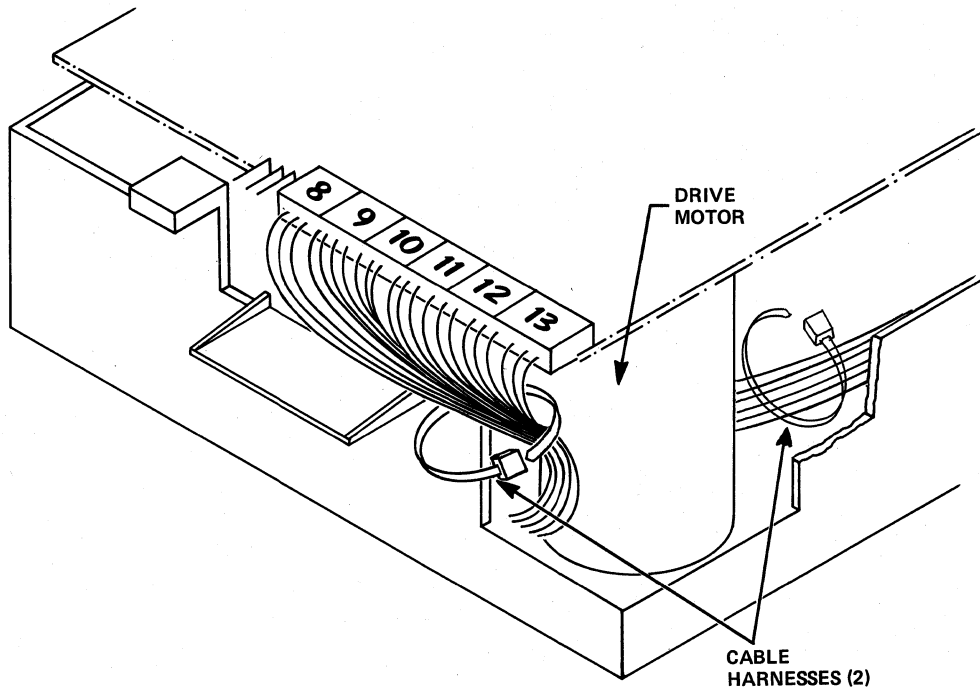

Figure 5-9
Activity LED Assembly Cable Harnessing

5.6.3 Remove the retaining collar that holds the Activity LED Assembly cables to the LED grommet by taking a pair of needle nose pliers and gently pulling the retaining collar away from the front panel (see Figure 5-10).

5.6.4 Snap out the Activity LED Assembly from the LED grommet.

5.6.5 Remove the entire Activity LED Assembly from the disk drive.

5.6.6 Snap the new Activity LED Assembly into the front panel LED grommet.

5.6.7 Push the retaining collar over the LED grommet.

5.6.8 Install a new cable harness to attach the Activity LED Assembly and the Write Protect Switch Assembly to the chassis by putting the cable harness through the two (2) holes in the bottom of the chassis (see Figure 5-9).

NOTE

Smooth out the cables before harnessing them.

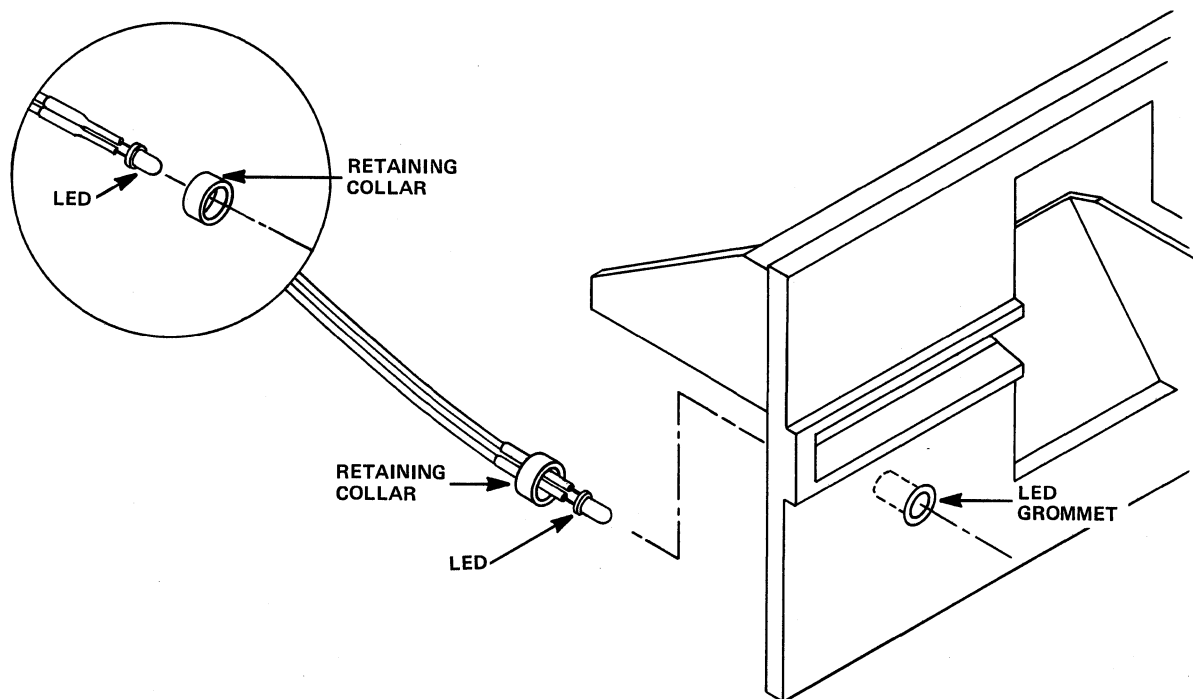

Figure 5-10
Activity LED Assembly Retaining Collar and LED Grommet

- 5.6.9 Install a new cable harness around the bundle of wires, including the new Activity LED Assembly cables, that are located at the back of the drive motor (see Figure 5-9).
- 5.6.10 Reinstall the Logic PCBA (see Section 5.2).
- 5.6.11 Verify that the front panel Activity LED Assembly operates by using a computer or an exerciser.

5.7 FRONT PANEL

5.7.1 Remove the Logic PCBA (see Section 5.2).

5.7.2 Using a pair of needle nose pliers, remove the two (2) bushings located on the right-hand and the left-hand top sides of the front panel by pulling up on them while using a twisting motion (see Figure 5-11).

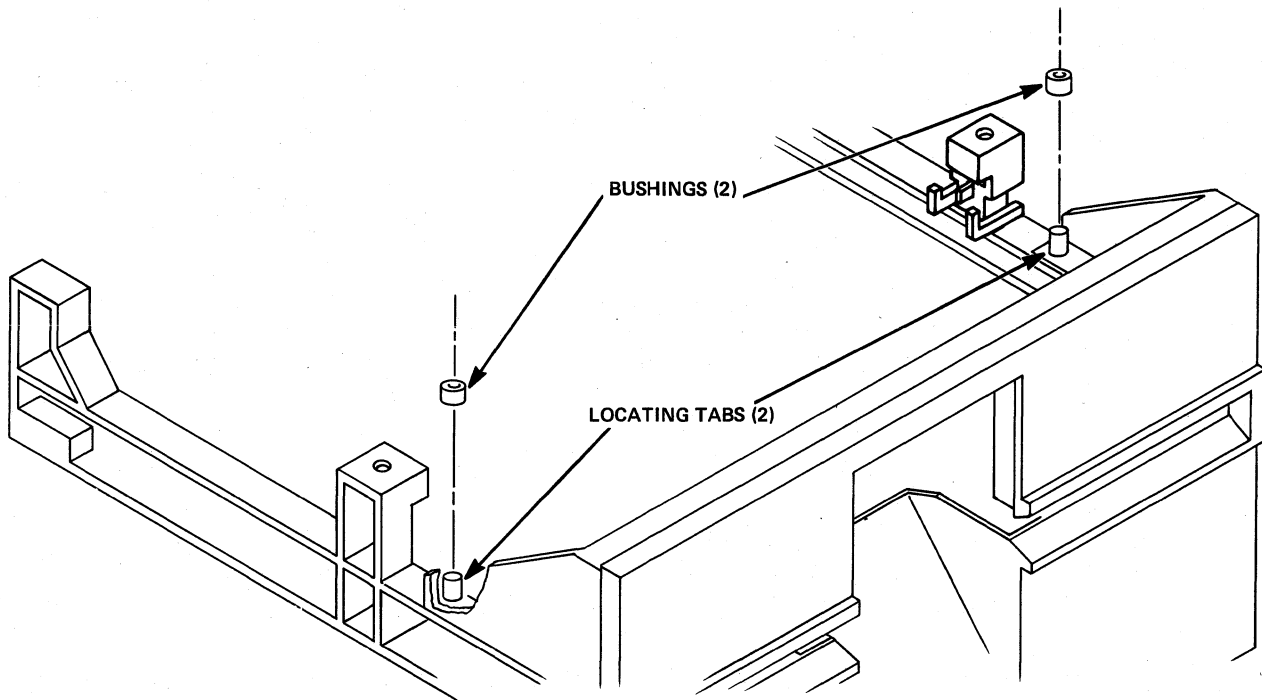

Figure 5-11
Front Panel Bushings

5.7.3 Remove the retaining collar that attaches the Activity LED Assembly to the front panel by taking a pair of needle nose pliers and gently pulling the retaining collar away from the front panel (see Figure 5-12).

NOTE

Slide the retaining collar over the Activity LED Assembly.

5.7.4 Snap out the Activity LED Assembly from its grommet.

5.7.5 With a Phillips screwdriver, remove the two (2) mounting screws that attach the front panel to the chassis (see Figure 5-13).

NOTE

These two mounting screws are located underneath the front end of the disk drive.

5.7.6 Lift up the front panel, and remove it from the chassis.

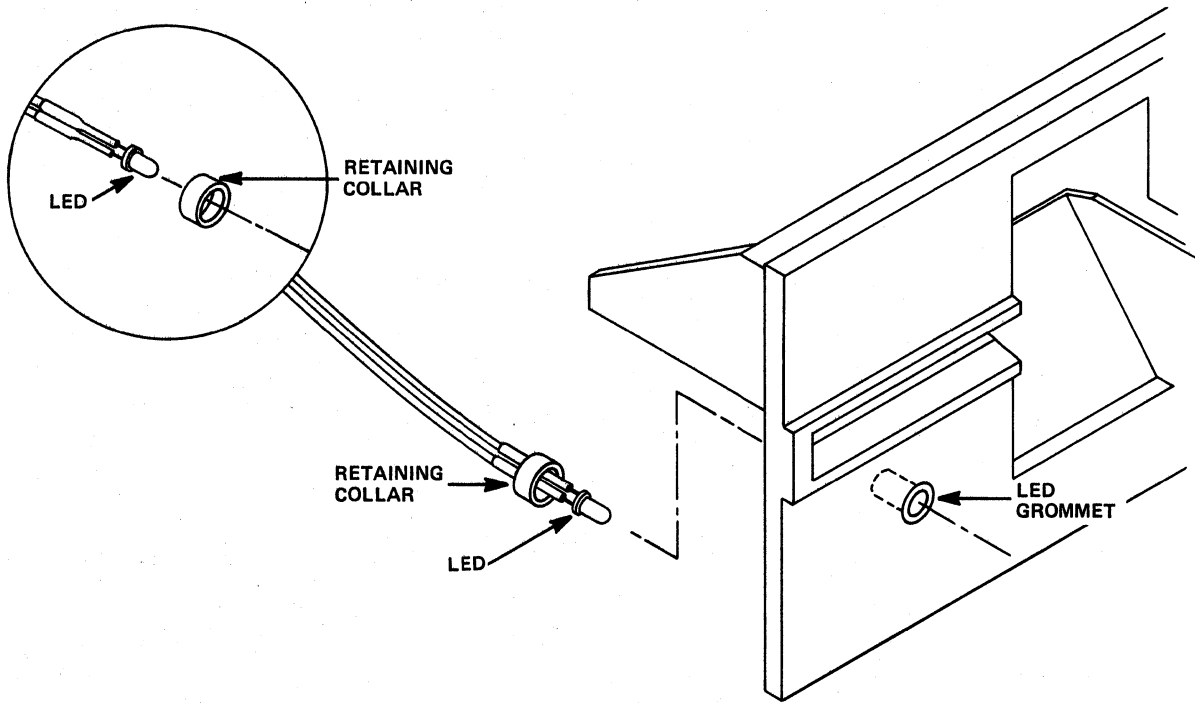

Figure 5-12
Activity LED Assembly Retaining Collar and Grommet

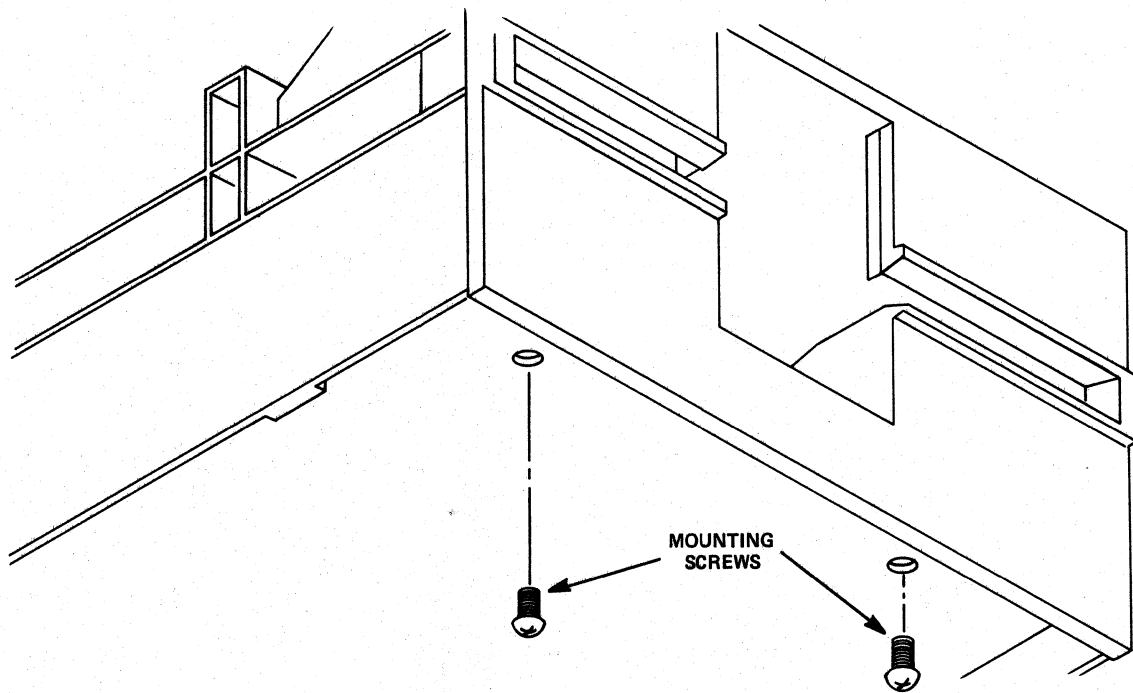

Figure 5-13
Front Panel Mounting Screws

5.7.7 Taking the new front panel, place the front door in its tracks on the front panel, and place the new front panel on the rail pins (see Figure 5-11).

5.7.8 After upending the disk drive, using a Phillips screwdriver, reinstall the two (2) mounting screws that attach the front panel to the chassis (see Figure 5-13).

5.7.9 Push the Activity LED Assembly into its grommet.

NOTE

The Activity LED Assembly usually makes a clicking noise when it is firmly pushed into the LED grommet.

5.7.10 Push the Activity LED Assembly retaining collar over the back of the LED grommet (see Figure 5-12).

5.7.11 Install two (2) new bushings on the right-hand and the left-hand sides of the front panel (see Figure 5-11).

5.7.12 Put a small drop of glue (Permatbond, Superglue, or other cyanoacrylic adhesive) on top of each bushing.

5.7.13 Reinstall the Logic PCBA (see Section 5.2).

5.8 GUIDE RAIL

5.8.1 Remove the Logic PCBA (see Section 5.2).

5.8.2 With needlenose pliers, remove the bushing from the front panel locating tab on the guide rail that is to be replaced (see Figure 5-14).

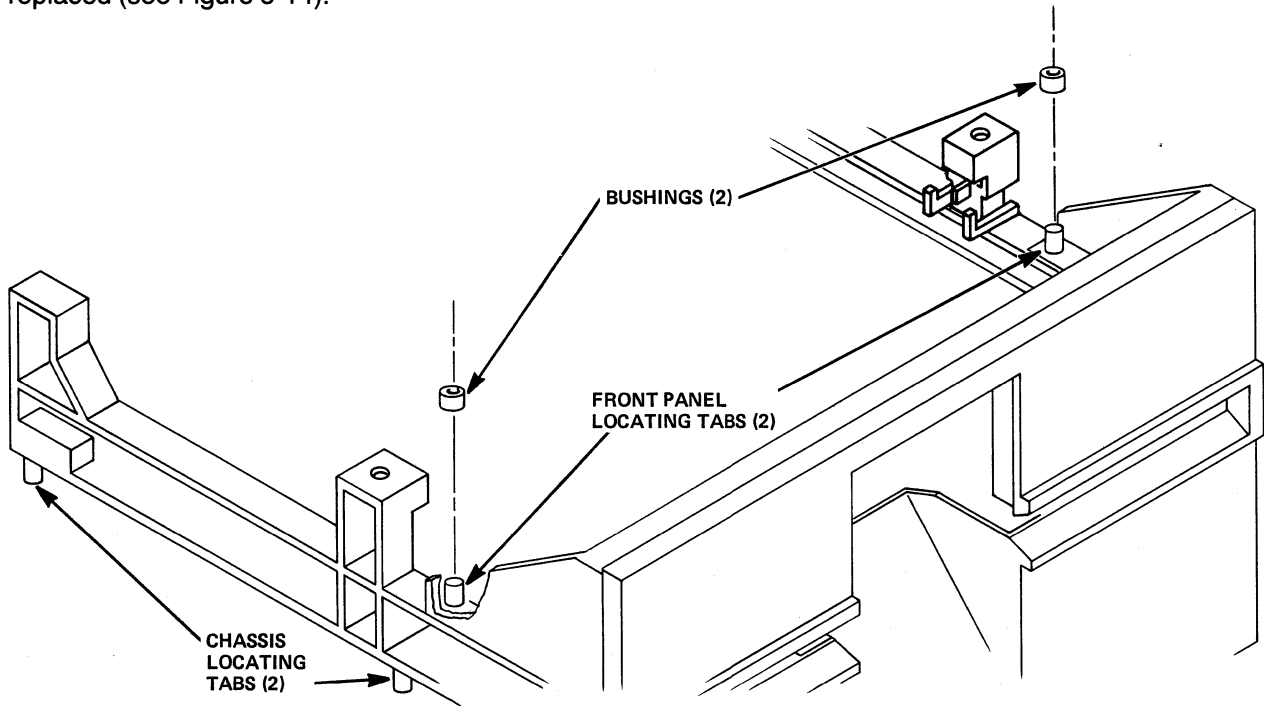

Figure 5-14
Front Panel Bushings, and Locating Tabs

5.8.3 With a Phillips screwdriver, remove the two (2) mounting screws located near the front of the disk drive, underneath the chassis, that attach the front panel to the chassis (see Figure 5-13).

5.8.4 Pull up the front panel slightly from the guide rail that is to be replaced.

NOTE

If the right-hand guide rail is to be replaced, detach the head cables from the two (2) posts.

5.8.5 With a flat blade screwdriver inserted between the guide rail and the chassis, pry up, from both of its ends, the guide rail that is to be replaced, and remove it.

5.8.6 If one of the two (2) chassis locating tabs, located underneath the guide rail that has been removed, has broken off inside the chassis (see Figure 5-14), clean out the hole completely, using a one-eighth (1/8) inch drill or a soldering iron to melt the plastic, then remove the debris.

NOTE

Take care not to enlarge the hole in the chassis.

- 5.8.7 Press in the new guide rail evenly.
- 5.8.8 Push down on the front panel until it is back in place.
- 5.8.9 After turning the disk drive upside down, reinstall the two (2) mounting screws located near the front of the chassis with a Phillips screwdriver.
- 5.8.10 After turning the disk drive right-side up, put the bushing over the front panel locating tab.
- 5.8.11 Put a small drop of glue (Permabond, Superglue, or other cyanoacrilic adhesive) on top of the front panel locating tab.
- 5.8.12 If the right-hand guide rail has been replaced, reloop the head cables over the two (2) guide rail posts.
- 5.8.13 Reinstall the Logic PCBA (see Section 5.2).
- 5.8.14 If the left-hand guide rail has been replaced, verify the Write Protect Switch and its adjustment (see Section 5.12.14).
- 5.8.15 Reinstall the Logic PCBA (see Section 5.2).

5.9 INDEX ASSEMBLY

5.9.1 Remove the Logic PCBA (see Section 5.2).

5.9.2 Remove the harness that attaches the index emitter sensor cable to the Cone Lever Assembly (see Figure 5-15).

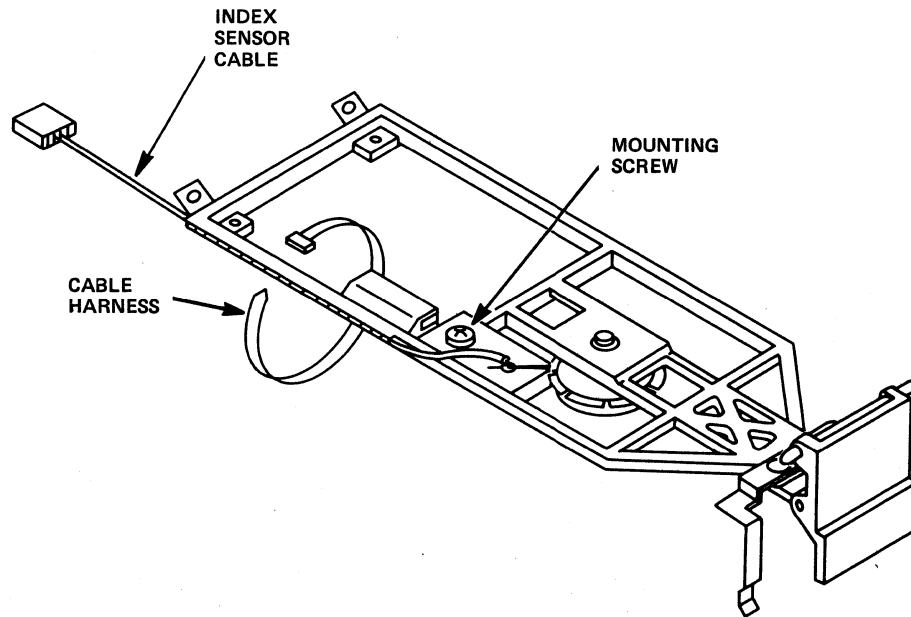

Figure 5-15
Index Emitter Sensor Harnessing and Mounting

5.9.3 Remove the harness that holds the bundle of cables at the rear of the disk drive.

5.9.4 With a Phillips screwdriver, remove the mounting screw that attaches the index emitter sensor to the Cone Lever Assembly.

NOTE

The Index Assembly is comprised of the index emitter sensor and the index detector sensor.

5.9.5 Lift out the index emitter sensor holder from the disk drive.

5.9.6 With a Phillips screwdriver, remove the mounting screw from the bottom of the disk drive that attaches the index detector sensor holder to the chassis (see Figure 5-16).

5.9.7 Lift out the index detector sensor holder from the disk drive.

5.9.8 Place the new index emitter sensor holder into the disk drive.

5.9.9 With a Phillips screwdriver, mount the new index emitter sensor holder to the Cone Lever Assembly, using its mounting screw.

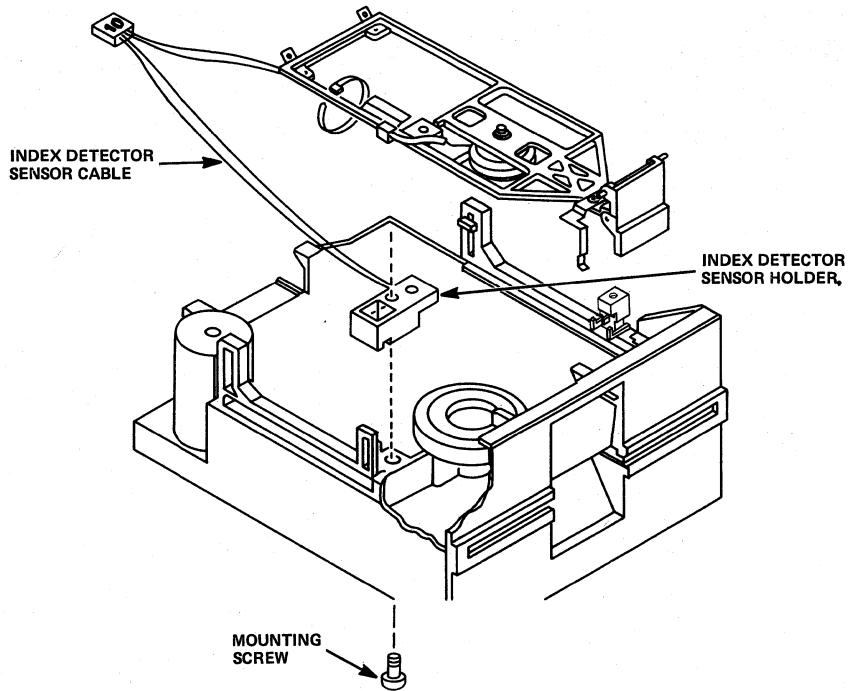

Figure 5-16
Index Detector Sensor Mounting Screw and Cable

5.9.10 Place the new index detector sensor holder in the top of the chassis.

5.9.11 With a Phillips screwdriver, mount the index detector sensor holder to the chassis, using its mounting screw, while holding the disk drive upside down.

5.9.12 After turning the disk drive upright, position all sensor cables (see Figures 5-15 and 5-17), and smooth them out.

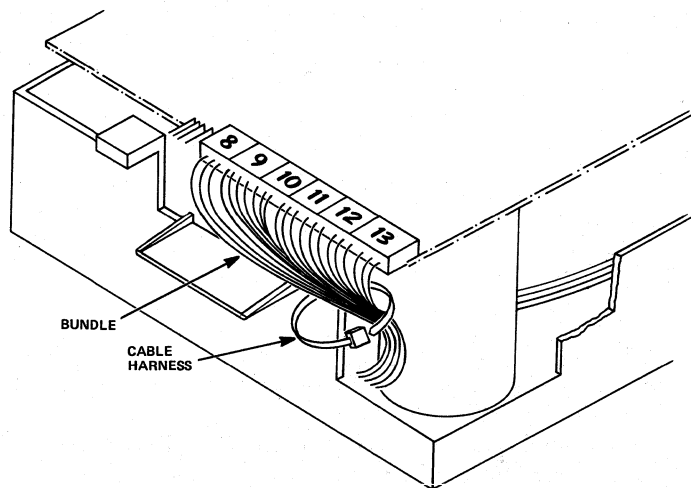

Figure 5-17
Index Emitter and Index Detector Sensor Cables and Bundle

- 5.9.13 Harness the index emitter sensor cables and the index detector sensor cables to the bundle (see Figure 5-17) located at the rear of the disk drive.
- 5.9.14 Insert a diskette into the disk drive.
- 5.9.15 Check to ensure that the aforementioned sensor cables do not touch the diskette, the Cone Lever Assembly, and the Carriage Assembly.
- 5.9.16 Reinstall the Logic PCBA (see Section 5.2).
- 5.9.17 Adjust the index-to-data timing (see Section 2.3.2.1).

5.10 DRIVE MOTOR ASSEMBLY

5.10.1 Remove the Logic PCBA (see Section 5.2).

5.10.2 Detach Connector P21 from the Servo PCBA located at the back of the disk drive.

5.10.3 Cut the cable harness that holds Connector P21.

5.10.4 After turning the disk drive upside down, remove the drive belt (see Section 5.1).

5.10.5 With a Phillips screwdriver, remove the two (2) mounting screws and the two (2) shoulder washers that attach the Drive Motor Assembly to the chassis (see Figure 5-18).

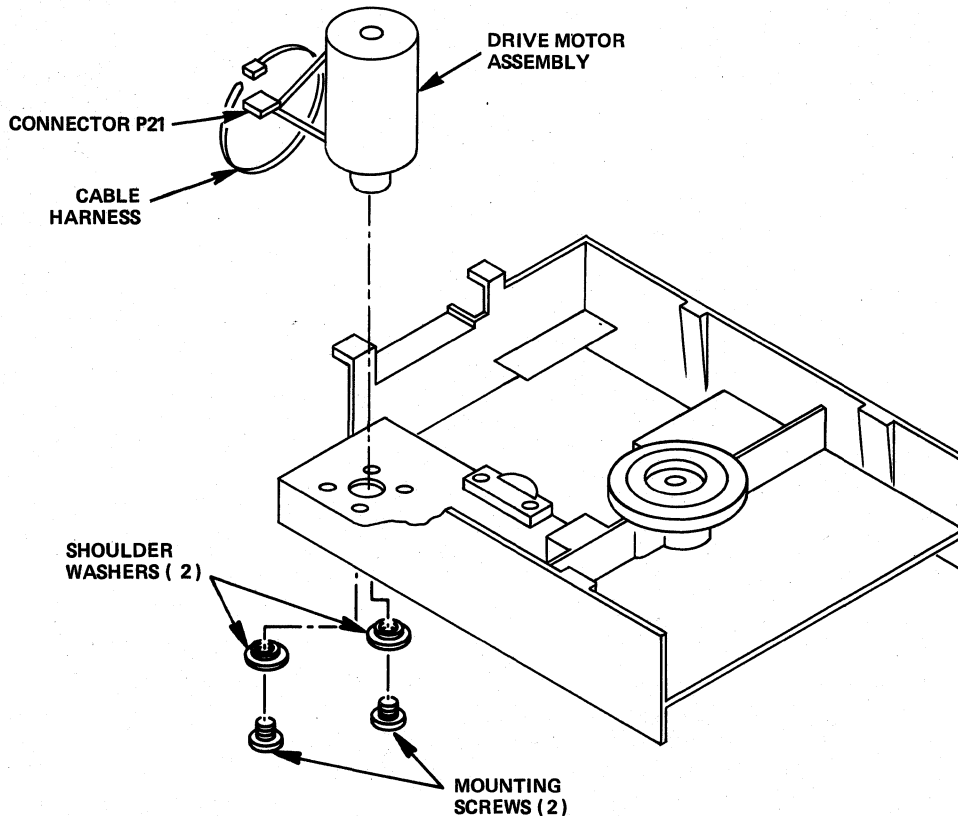

Figure 5-18
Drive Motor Assembly Harnessing and Mounting

NOTE

Save the mounting screws and the shoulder washers.

5.10.6 Remove the Drive Motor Assembly from the chassis.

5.10.7 Insert the pulley of the new Drive Motor Assembly through the bottom of the chassis (see Figure 5-19).

5.10.8 Rotate the Drive Motor Assembly until its two (2) tapped holes are aligned with two (2) of the holes in the chassis.

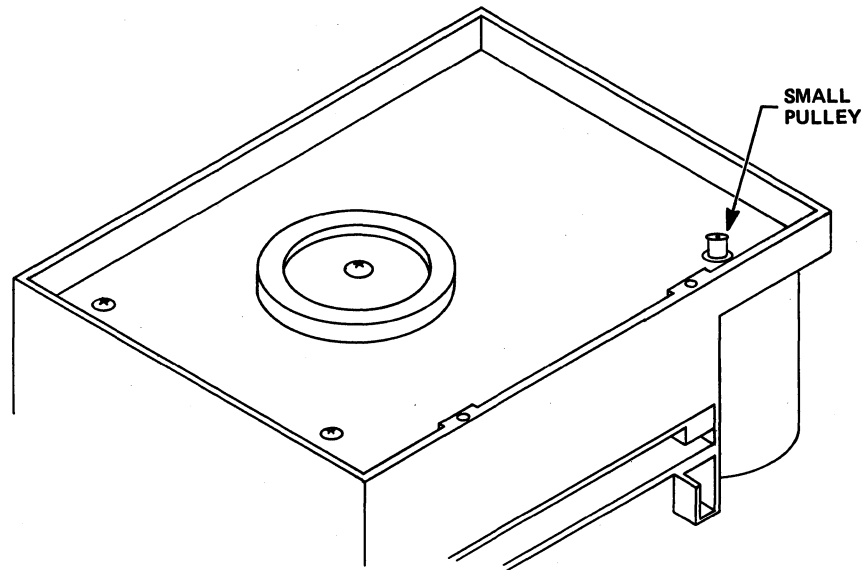

Figure 5-19
Drive Motor Assembly Pulley

NOTE

Ensure that Connector P21's cables are closer to the Servo PCBA than to the front of the disk drive.

- 5.10.9 With a Phillips screwdriver, mount the Drive Motor Assembly to the chassis, using the two (2) mounting screws and the two (2) shoulder washers previously set aside.
- 5.10.10 Reinstall the drive belt (see Section 5.1).
- 5.10.11 Plug Connector P21 into the Servo PCBA (see Figure 5-18).
- 5.10.12 Reinstall the Logic PCBA (see Section 5.2).
- 5.10.13 Check the Instantaneous Speed Variation (ISV) (see Section 2.1.2).
- 5.10.14 If the ISV meets the specification, adjust the drive motor speed (see Section 2.1.1).
- 5.10.15 Recheck the ISV (see Section 2.1.2).

5.11 TRACK 00 SENSOR ASSEMBLY

5.11.1 Remove the Logic PCBA (see Section 5.2).

5.11.2 Cut the two (2) harnesses that hold the bundle of cables at the back of the drive motor, and that attach the cables to the bottom of the chassis (see Figure 5-20).

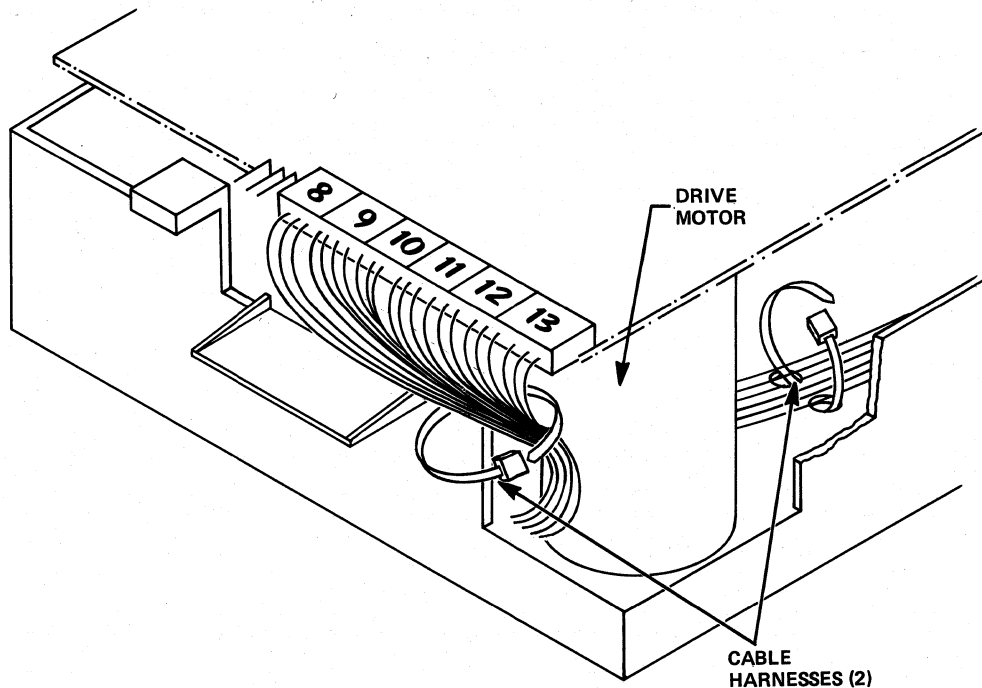

Figure 5-20
Track 00 Sensor Assembly Cable Harnessing

5.11.3 With a flat blade screwdriver, remove the E-ring from the Track 00 Sensor Assembly's adjustment screw located on the inside of the disk drive between the switch and its bracket (see Figure 5-21).

5.11.4 Move the head carriage toward the front of the disk drive, i.e., away from the Track 00 Sensor Assembly.

5.11.5 With a Phillips screwdriver, remove the mounting screw that attaches the Track 00 Sensor Assembly to the chassis (see Figure 5-22).

5.11.6 Remove the Track 00 Sensor Assembly by pulling it toward the front of the disk drive.

5.11.7 Put the new Track 00 Sensor Assembly into the disk drive near the left-hand rear of the chassis.

5.11.8 Push the new Track 00 Sensor Assembly toward the rear of the disk drive until its mounting hole is aligned with the mounting hole in the chassis.

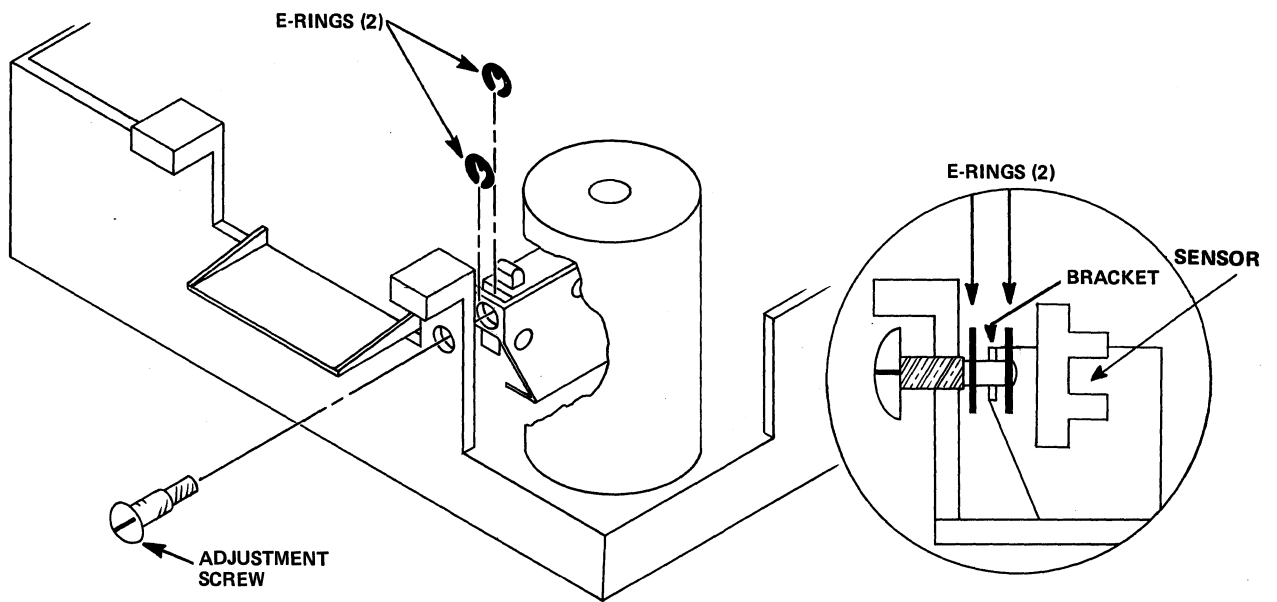

Figure 5-21
Track 00 Sensor Assembly E-Rings and Adjustment Screw

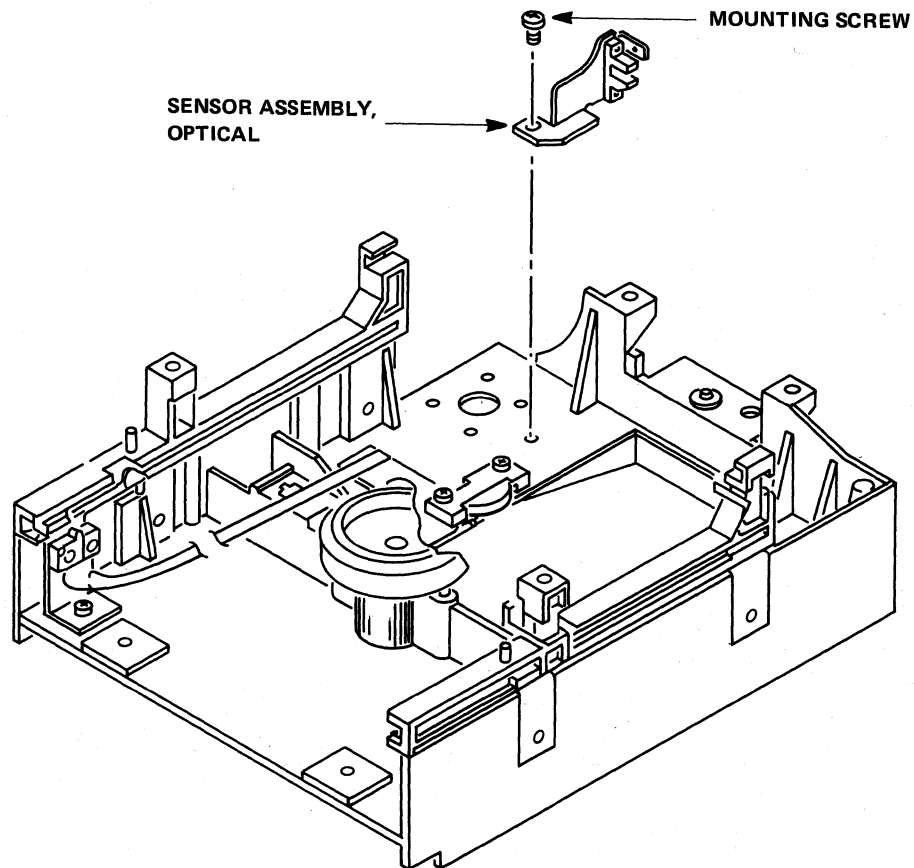

Figure 5-22
Track 00 Sensor Assembly and Mounting Screw

- 5.11.9 Make sure that there are no cables underneath the Track 00 Sensor Assembly.
- 5.11.10 With a Phillips screwdriver, install and tighten the mounting screw that attaches the Track 00 Sensor Assembly to the bottom of the chassis (see Figure 5-22).
- 5.11.11 Reinstall the E-ring with an E-ring insertion tool.
- 5.11.12 Harness the new Track 00 Sensor Assembly's cables, the Activity LED Assembly's cables, and the Write Protect Switch Assembly's cables to the bottom of the chassis (see Figure 5-20).
- 5.11.13 Harness the bundle of cables, including the new Track 00 Sensor Assembly's cables, located at the back of the drive motor (see Figure 5-20).
- 5.11.14 Reinstall the Logic PCBA (see Section 5.2).
- 5.11.15 To adjust the Track 00 Sensor Assembly, loosen the mounting screw, and move the switch in or out by turning the adjustment screw (see Section 2.6).

NOTE

There is no Track 00 output to the controller until the drive motor phase is correct (see Section 3.3.2.2).

5.12 WRITE PROTECT SWITCH ASSEMBLY

5.12.1 Visually ensure that the arm on the Write Protect Switch Assembly moves the switch and makes a clicking noise when the arm is pushed down (see Figure 5-23).

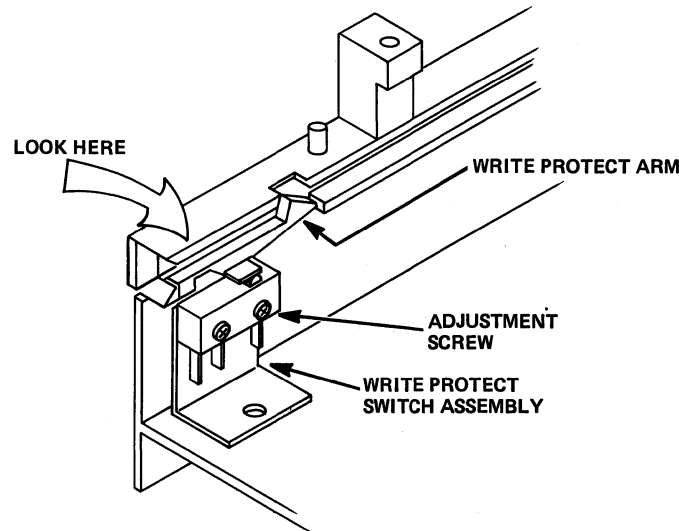

Figure 5-23
Write Protect Switch Assembly Arm and Adjustment Screw

5.12.2 Remove the Logic PCBA (see Section 5.2).

5.12.3 With a Phillips screwdriver, remove the mounting screw that attaches the Write Protect Switch Assembly to the side of the chassis (see Figure 5-24).

5.12.4 Cut the harness that attaches the Write Protect Switch Assembly cables and the Activity LED Assembly cables to the bottom of the chassis (see Figure 5-25).

5.12.5 Cut the harness that attaches the Write Protect Switch Assembly and the Activity LED Assembly cables to the bundle of wires that go to the PCBA (see Figure 5-25).

5.12.6 Remove the Write Protect Switch Assembly from the disk drive.

5.12.7 Place the new Write Protect Switch Assembly in position on the left-hand side of the chassis near the front.

5.12.8 Using a Phillips screwdriver, mount the new Write Protect Switch Assembly with its mounting screw.

5.12.9 After smoothing out the Write Protect Switch Assembly cables and the Activity LED Assembly cables, harness them to the bottom of the chassis, routing the wires between the Drive Motor Assembly and the Track 00 Switch Assembly (see Figure 5-25).

5.12.10 Harness the bundle of wires at the back of the disk drive, including the new Write Protect Switch Assembly cables in the bundle (see Figure 5-25).

5.12.11 Reinstall the Logic PCBA (see Section 5.2).

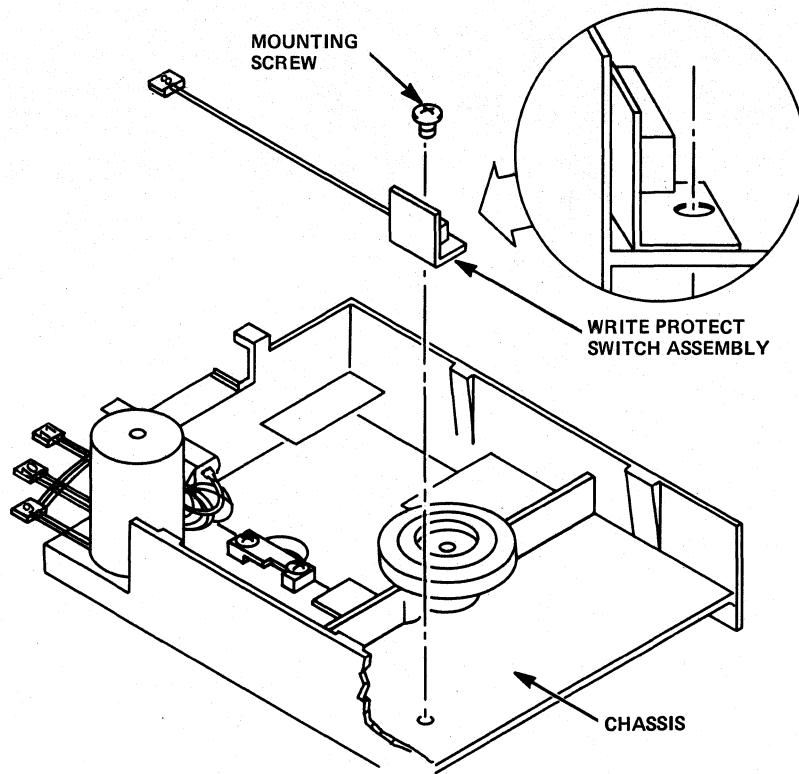

Figure 5-24
Write Protect Switch Assembly Mounting Screw and Connector P8

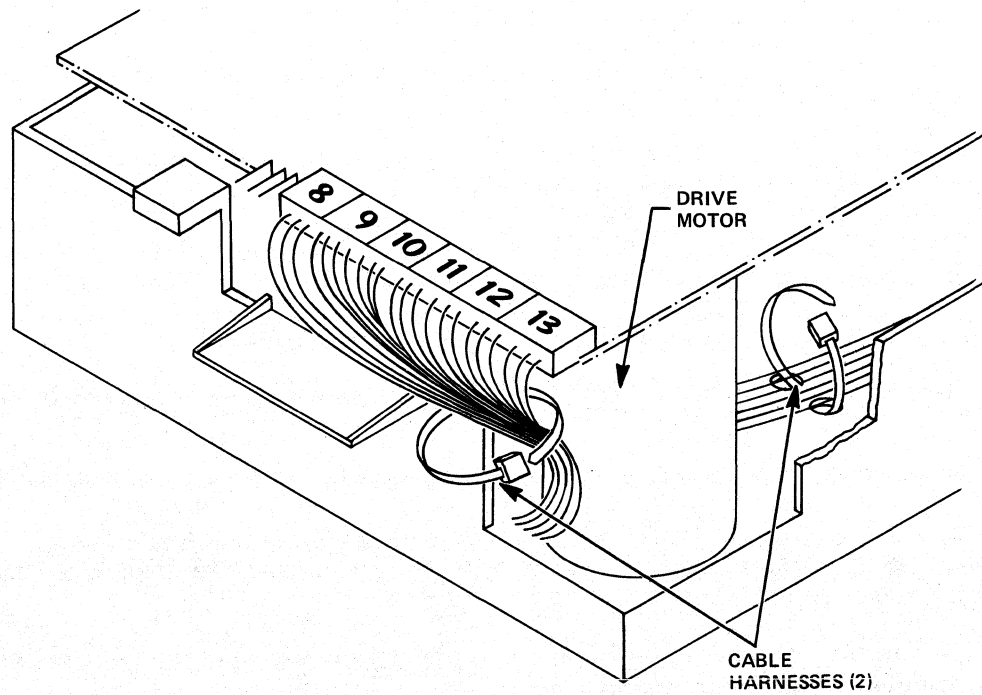

Figure 5-25
Write Protect Switch Assembly Cable Harnessing

- 5.12.12 Verify the output of the Write Protect Switch Assembly by inserting a diskette.
- 5.12.13 Reverify the output of the Write Protect Switch Assembly.
- 5.12.14 Adjust the Write Protect Switch if necessary (see Section 2.5.4).

5.13 UPPER ARM ASSEMBLY (SINGLE-SIDED DRIVES ONLY)

5.13.1 Remove the Logic PCBA (see Section 5.2).

5.13.2 Close the front door located in the front panel.

5.13.3 Using a three-sixteenth (3/16) inch thin wall nut driver, remove the two (2) nuts that attach the upper arm and spring retainer to the Carriage Assembly (see Figure 5-26).

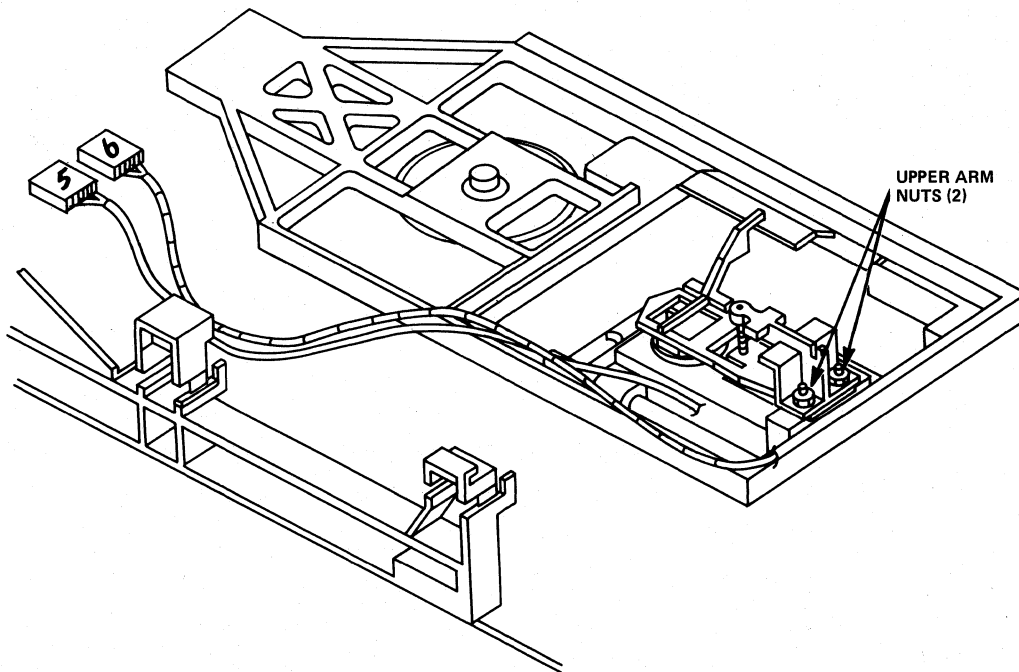

Figure 5-26
Nuts for Upper Arm and Spring Retainer

5.13.4 Carefully lift off the spring retainer and spring (see Figure 5-27).

5.13.5 Remove the Upper Arm Assembly.

5.13.6 Place the new Upper Arm Assembly on the two (2) set screws.

5.13.7 Carefully replace the spring and spring retainer (see Figure 5-27).

5.13.8 Ensuring that the spring is seated on both ends, reinstall but do not completely tighten the two (2) set screws that hold on the Upper Arm Assembly and the spring retainer.

5.13.9 Visually align the felt pad on the arm with the head (see Figure 5-28).

5.13.10 Tighten the two (2) set screws (see Figure 5-27).

5.13.11 Insert a diskette into the disk drive.

5.13.12 Visually check to ensure that the felt pad clears the disk when the front door is opened (see Figure 5-28).

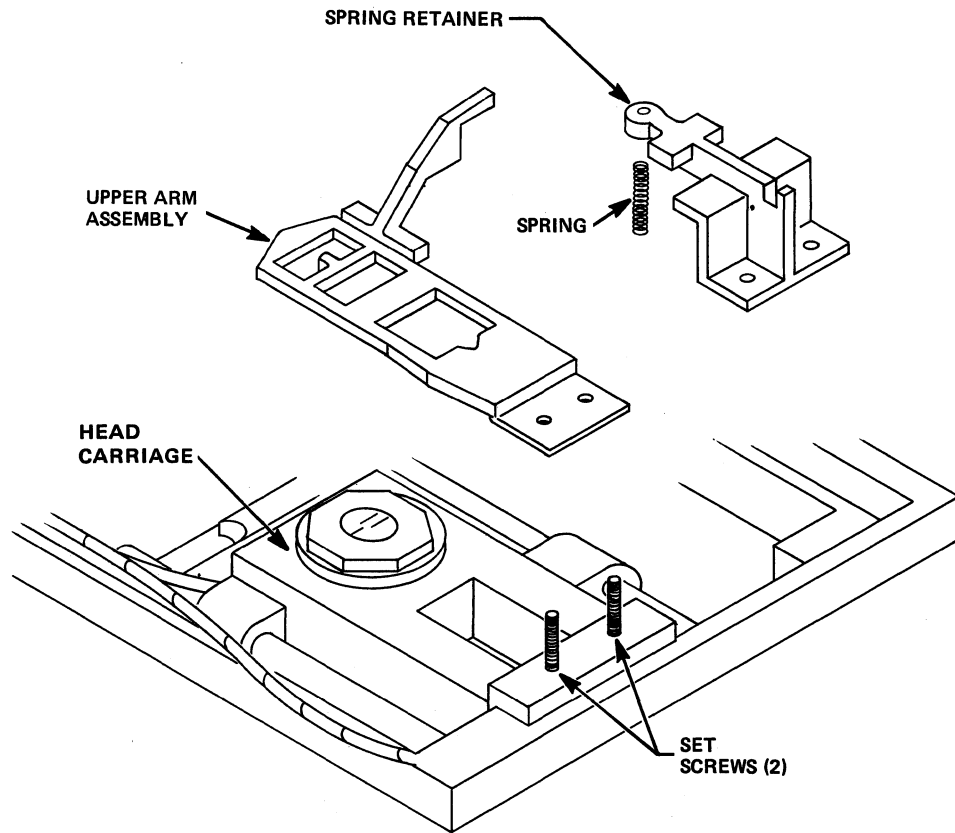

Figure 5-27
Upper Arm Assembly Parts

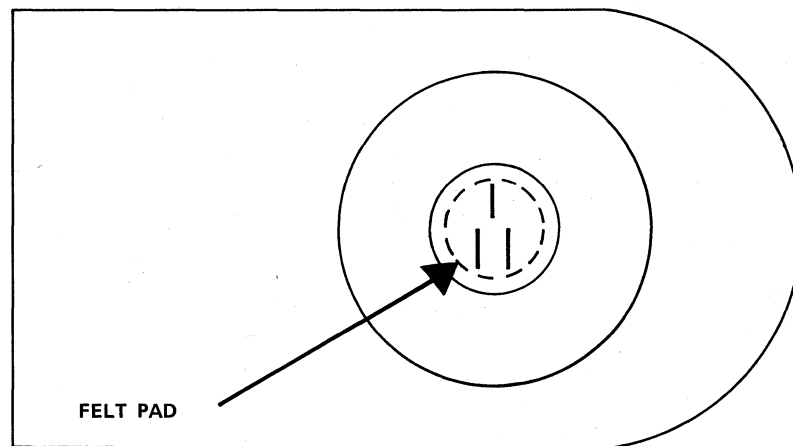

Figure 5-28
Felt Pad on Upper Arm

- 5.13.13 Reinstall the Logic PCBA (see Section 5.2).
- 5.13.14 Check the compliance (see Section 2.4).
- 5.13.15 Adjust the compliance if necessary (see Section 2.4.2).

5.14 MODULE ASSEMBLY

5.14.1 Remove the Logic PCBA (see Section 5.2).

5.14.2 Remove the Cone Lever Assembly (see Section 5.4).

5.14.3 With a Phillips screwdriver, remove the three (3) mounting screws and their flat washers that attach the Module Assembly to the chassis (see Figure 5-29).

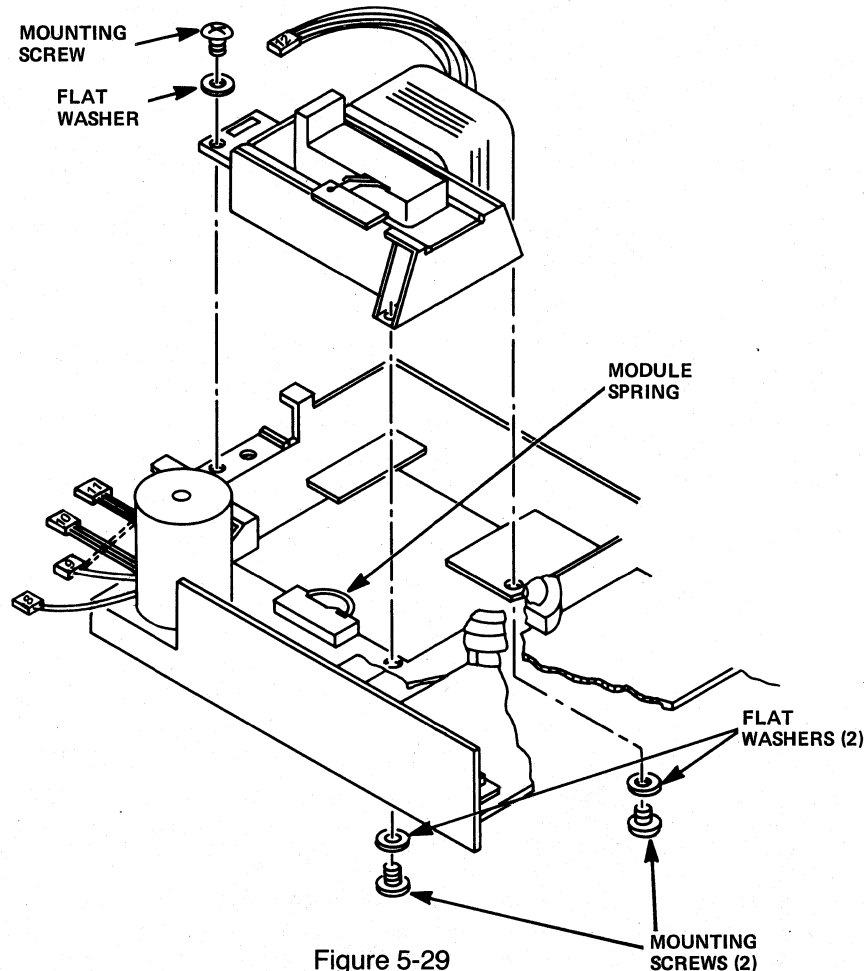

Figure 5-29
Module Assembly Parts

NOTE

One screw is located on the top middle at the back of the chassis. The other two screws are located underneath the middle of the chassis.

5.14.4 Remove the Module Assembly from the chassis by lifting it up.

5.14.5 Install the new Module Assembly by placing its left-hand side against the module spring, and by compressing the module spring to seat the other side of the Module Assembly.

- 5.14.6 With a Phillips screwdriver, reinstall the three (3) mounting screws and their flat washers that attach the Module Assembly to the chassis (see Figure 5-28).
- 5.14.7 Install the Cone Lever Assembly (see Section 5.4).
- 5.14.8 Install the Logic PCBA (see Section 5.2).
- 5.14.9 Complete all the maintenance checks (see Section II).
- 5.14.10 Make any necessary adjustments (see Section II).

5.15 SPINDLE ASSEMBLY

5.15.1 Remove the Logic PCBA (see Section 5.2).

5.15.2 Remove the Cone Lever Assembly (see Section 5.4).

5.15.3 Remove the drive belt (see Section 5.1).

5.15.4 Lay the disk drive on its side.

5.15.5 With a Phillips screwdriver, while holding the hub, remove the mounting screw and washer from the Spindle Assembly (see Figure 5-30).

5.15.6 Remove the large pulley from the bottom of the chassis (see Figure 5-30).

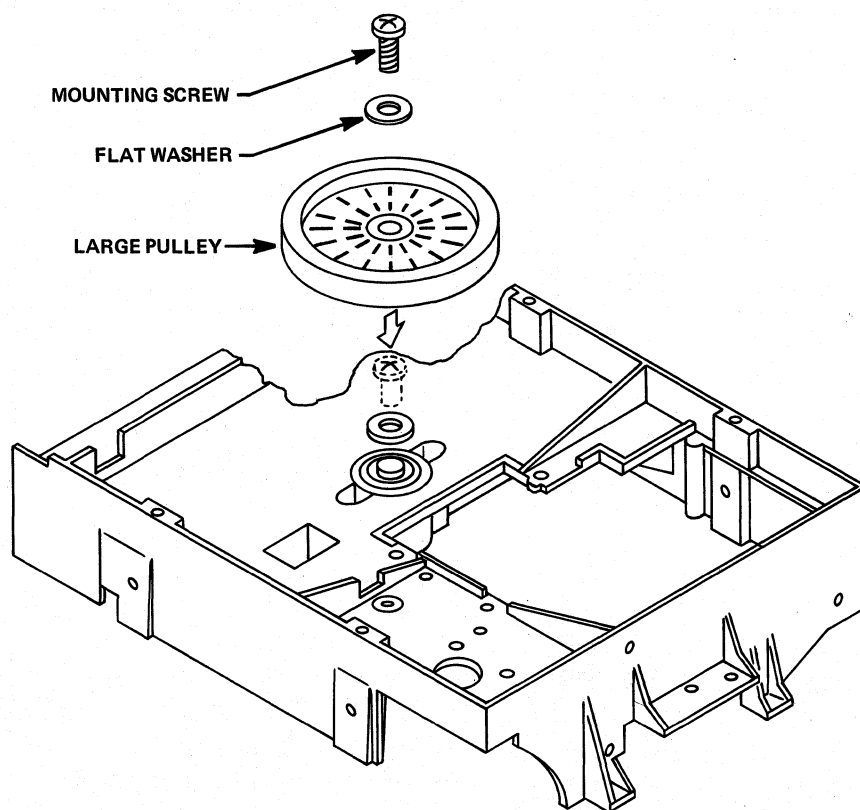

Figure 5-30
Spindle Assembly Mounting Screw, Washer, and Pulley

5.15.7 Using a one-quarter (1/4) inch wrench, loosen the two (2) hex head screws that attach the Spindle Assembly to the top of the chassis (see Figure 5-31).

5.15.8 Rotate the retainer counterclockwise until its slot openings no longer are held by the two (2) hex head screws (see Figure 5-31).

5.15.9 Remove the Spindle Assembly by pulling it up and away from the chassis.

5.15.10 Insert the new Spindle Assembly carefully into its mounting hole at the top of the chassis (see Figure 5-31).

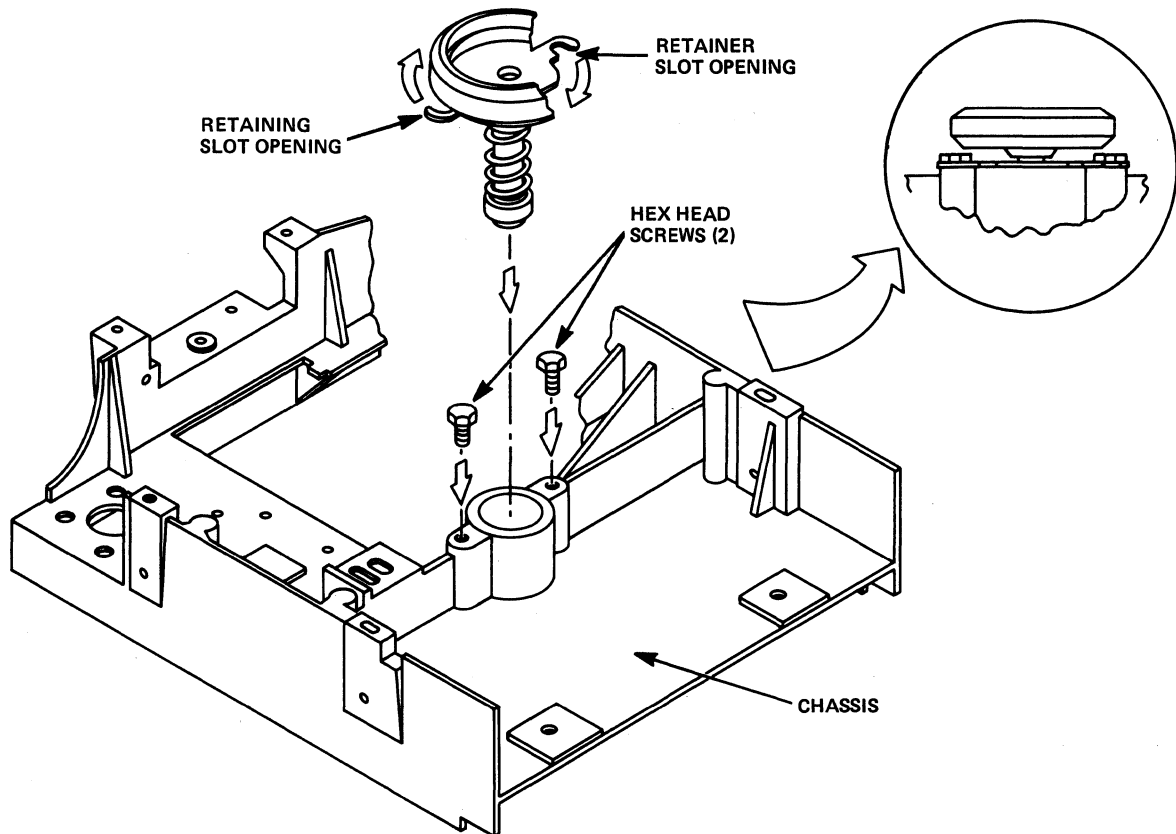

Figure 5-31
Spindle Assembly Retainer and Hex Head Screws

- 5.15.11 Engage the retainer by rotating it clockwise until its slot openings are under the two (2) hex head screws.
- 5.15.12 Using a one-quarter ($\frac{1}{4}$) inch wrench, tighten the two (2) hex head screws that attach the bearing retainer to the chassis (see Figure 5-31).
- 5.15.13 Lay the disk drive on its side.
- 5.15.14 With a Phillips screwdriver, while holding the hub, insert the large pulley, flat washer, and the mounting screw into the bottom of the chassis (see Figure 5-30).
- 5.15.15 While holding the hub, tighten the mounting screw (see Figure 5-30).
- 5.15.16 Check to ensure that the shaft does not wobble when the spindle turns.

NOTE

A wobble may indicate a bad bearing.

- 5.15.17 Reinstall the drive belt (see Section 5.1).

- 5.15.18 Reinstall the Cone Lever Assembly (see Section 5.4).
- 5.15.19 Reinstall the Logic PCBA (see Section 5.2).
- 5.15.20 Check the drive motor speed adjustment (see Section 2.1.1).
- 5.15.21 Check the Instantaneous Speed Variation (see Section 2.1.2).

5.16 LATCH PLATE ASSEMBLY

5.16.1 Remove the Logic PCBA (see Section 5.2).

5.16.2 With a Phillips screwdriver, loosen the two (2) mounting screws that attach the Latch Plate Assembly to the Cone Lever Assembly (see Figure 5-32).

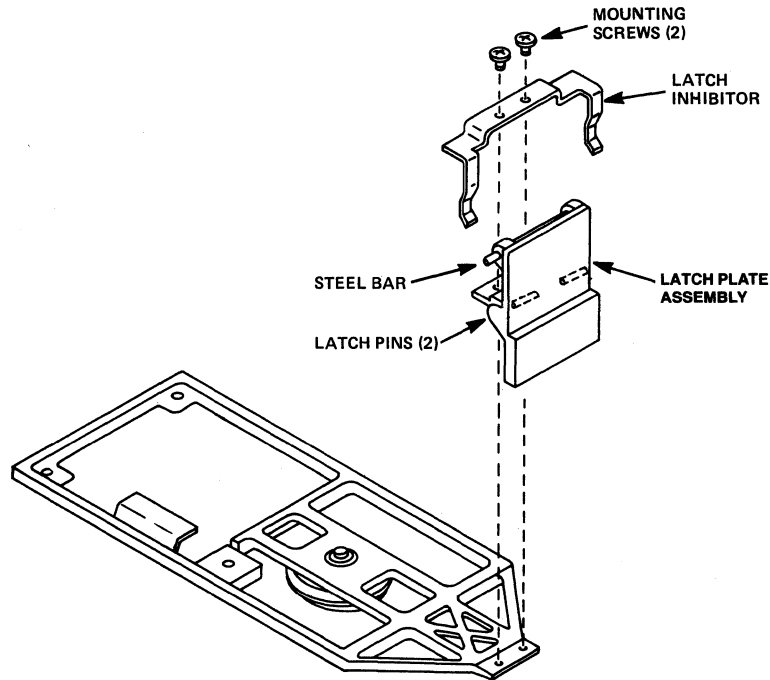

Figure 5-32
Latch Plate Assembly Mounting Screws and Latch Inhibitor

5.16.3 Remove the two (2) mounting screws from the Latch Plate Assembly.

5.16.4 Remove the latch inhibitor and the Latch Plate Assembly from the disk drive.

5.16.5 While holding the Cone Lever Assembly down, insert the new Latch Plate Assembly into its tracks.

5.16.6 Close the front door of the disk drive.

5.16.7 Still holding the Cone Lever Assembly down, place the latch inhibitor on top of the Latch Plate Assembly.

5.16.8 With a Phillips screwdriver, install but do not tighten the two (2) mounting screws that attach the latch inhibitor and the Latch Plate Assembly to the Cone Lever Assembly.

5.16.9 Open the front door located in the front panel.

5.16.10 Insert a diskette into the disk drive.

- 5.16.11 Close the front door.
- 5.16.12 Adjusting the latch inhibitor, align it so that it just touches the diskette as the front door is closed.
- 5.16.13 While holding the latch inhibitor in place, tighten the two (2) mounting screws with a Phillips screwdriver.
- 5.16.14 Reinstall the Logic PCBA (see Section 5.2).

APPENDIX I

PCB SCHEMATICS AND ASSEMBLY DRAWINGS

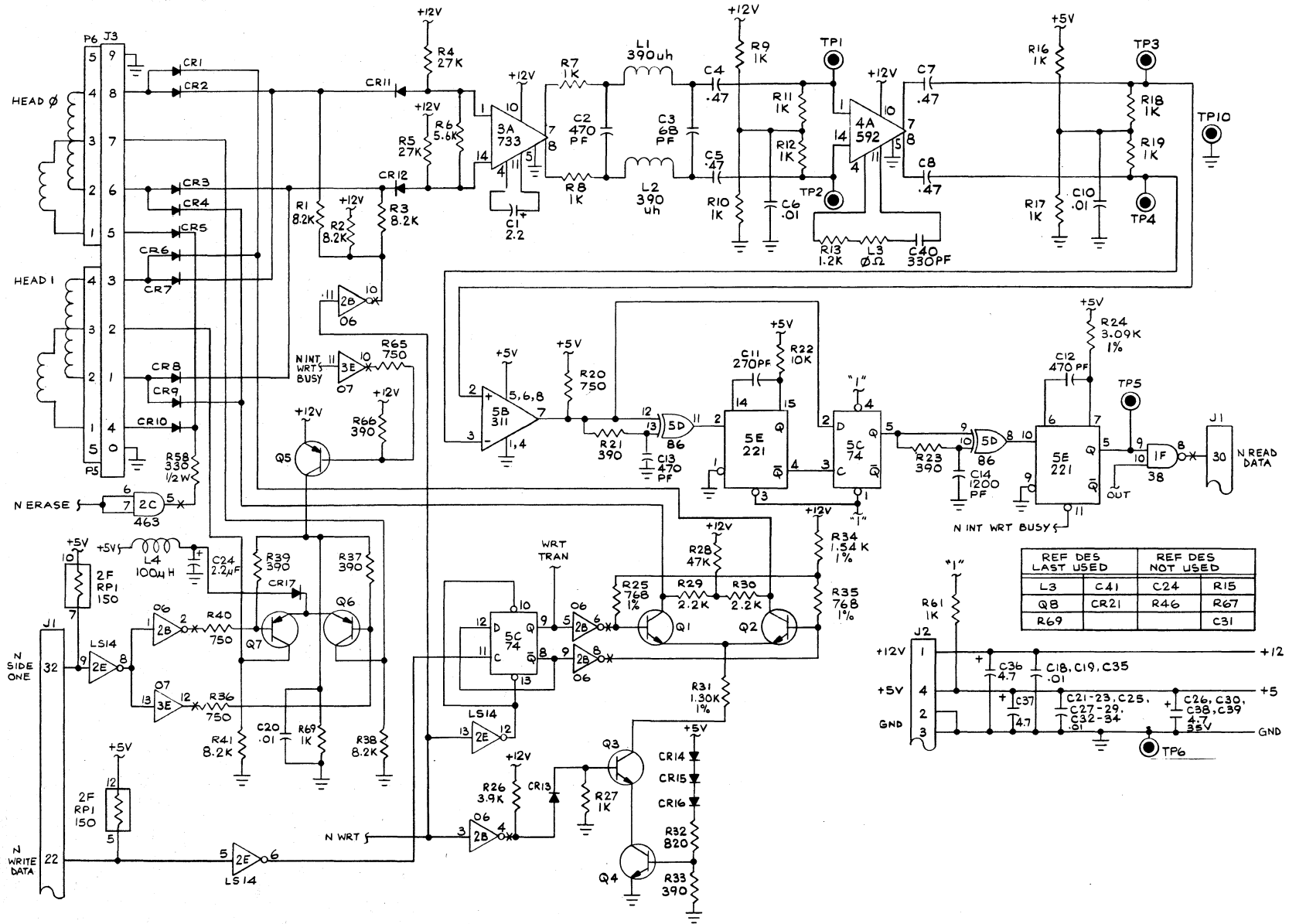

REF DES LAST USED	REF DES NOT USED
L3	C41
QB	CR21
R69	R46
	R15
	R67
	C31

**96/100 TPI, REWORK,
UNIPOLAR LOGIC SCHEMATIC**

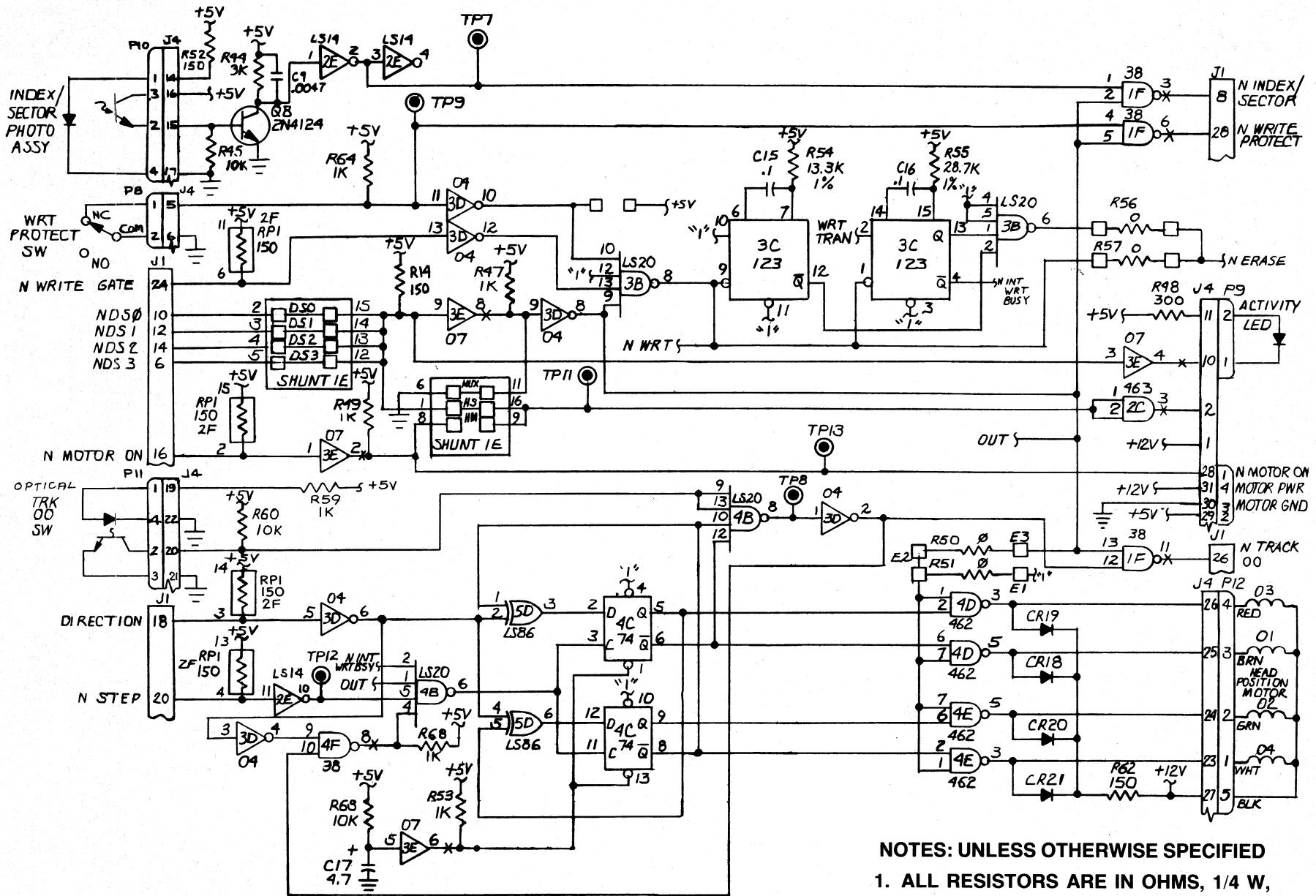

**96/100 TPI, REWORK,
UNIPOLAR LOGIC SCHEMATIC**

- NOTES: UNLESS OTHERWISE SPECIFIED**
1. ALL RESISTORS ARE IN OHMS, 1/4 W, 5%
 2. ALL CAPS ARE IN μ FD.
 3. ALL DIODES ARE IN 4446.
 4. ALL TRANSISTORS NPN ARE 2n4124 & FNP ARE 2N4125.

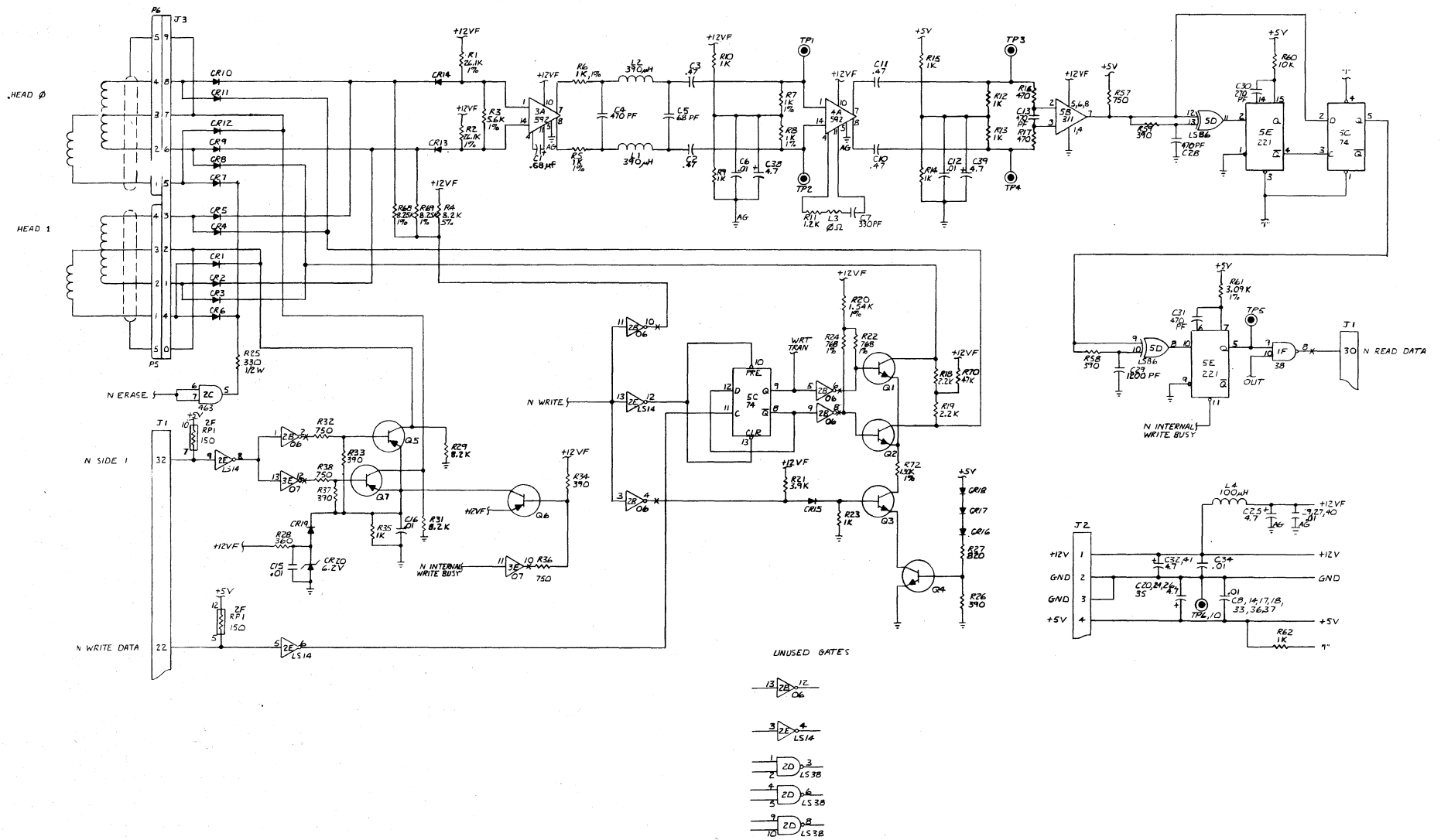

96/100 TPI
BIPOLAR LOGIC SCHEMATIC

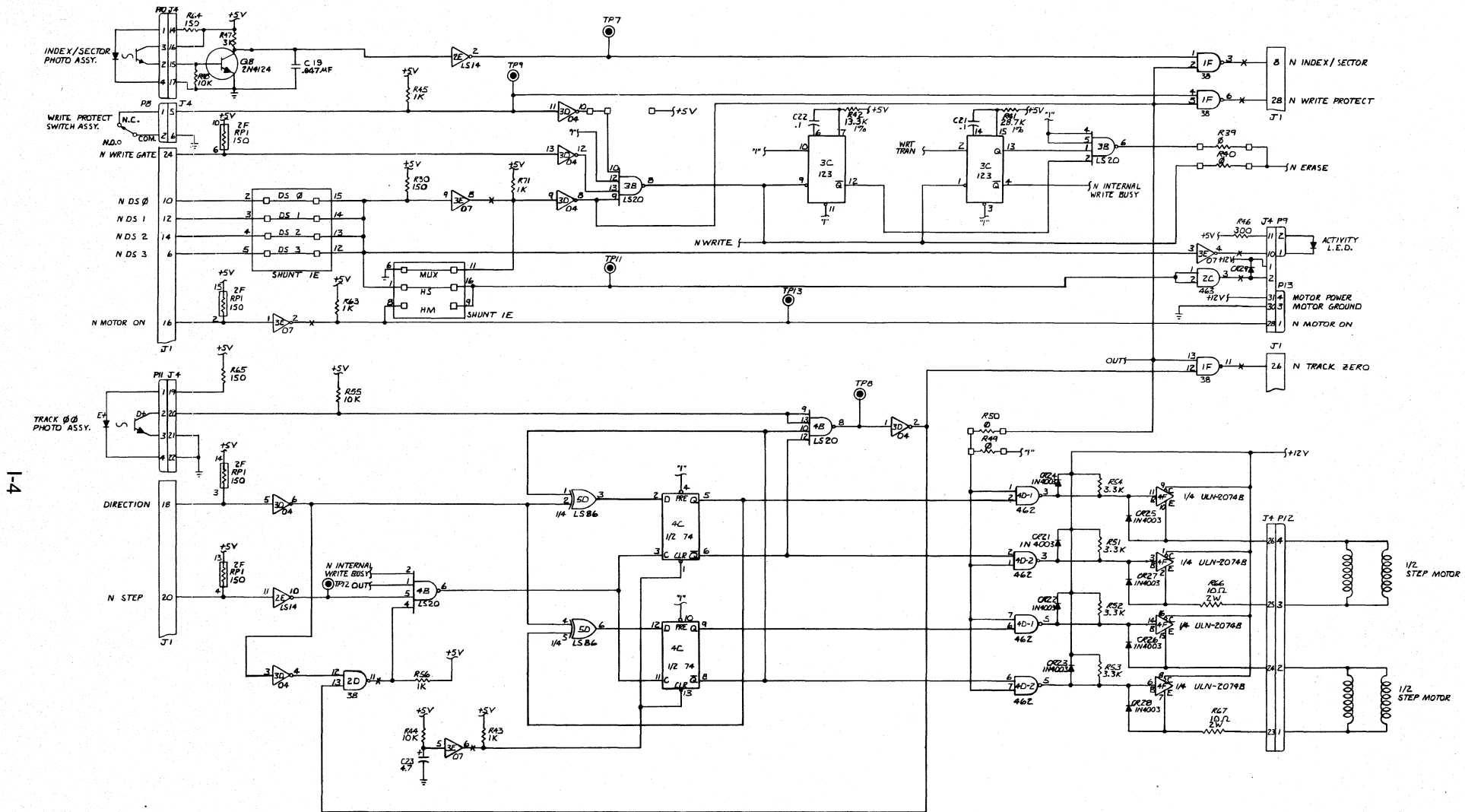

1-4

96/100 TPI
BIPOLAR LOGIC SCHEMATIC

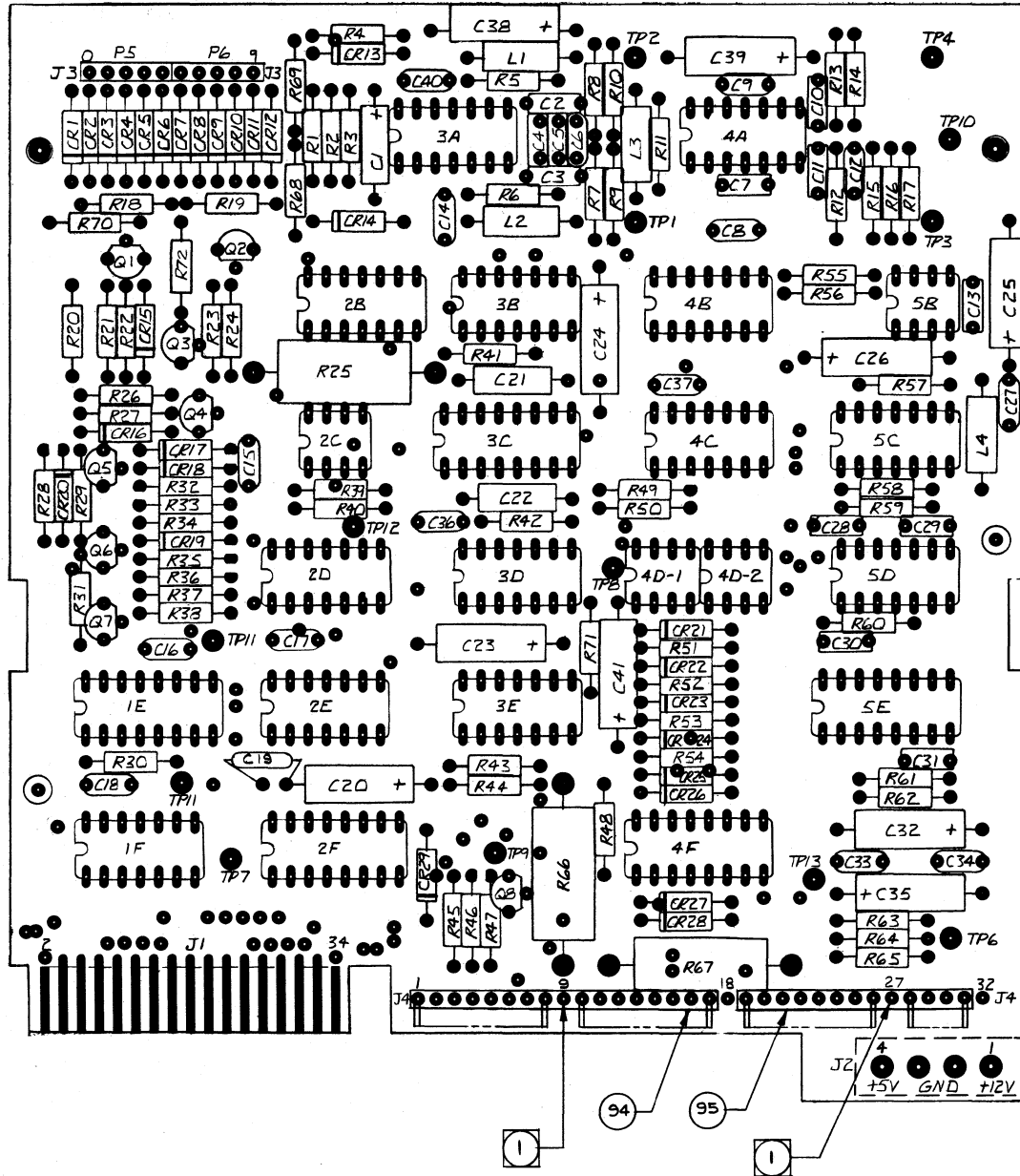

96/100 TPI
BIPOLAR LOGIC PCBA ASSEMBLY
DRAWING

NOTES: UNLESS OTHERWISE SPECIFIED

1. COMPONENT HEIGHT NOT TO EXCEED .35 ABOVE P.C. BOARD.
2. MAXIMUM PENETRATION OF COMPONENT LEADS BELOW BOARD AFTER ASSEMBLY AND TRIMMING SHALL NOT EXCEED .08 MAX.

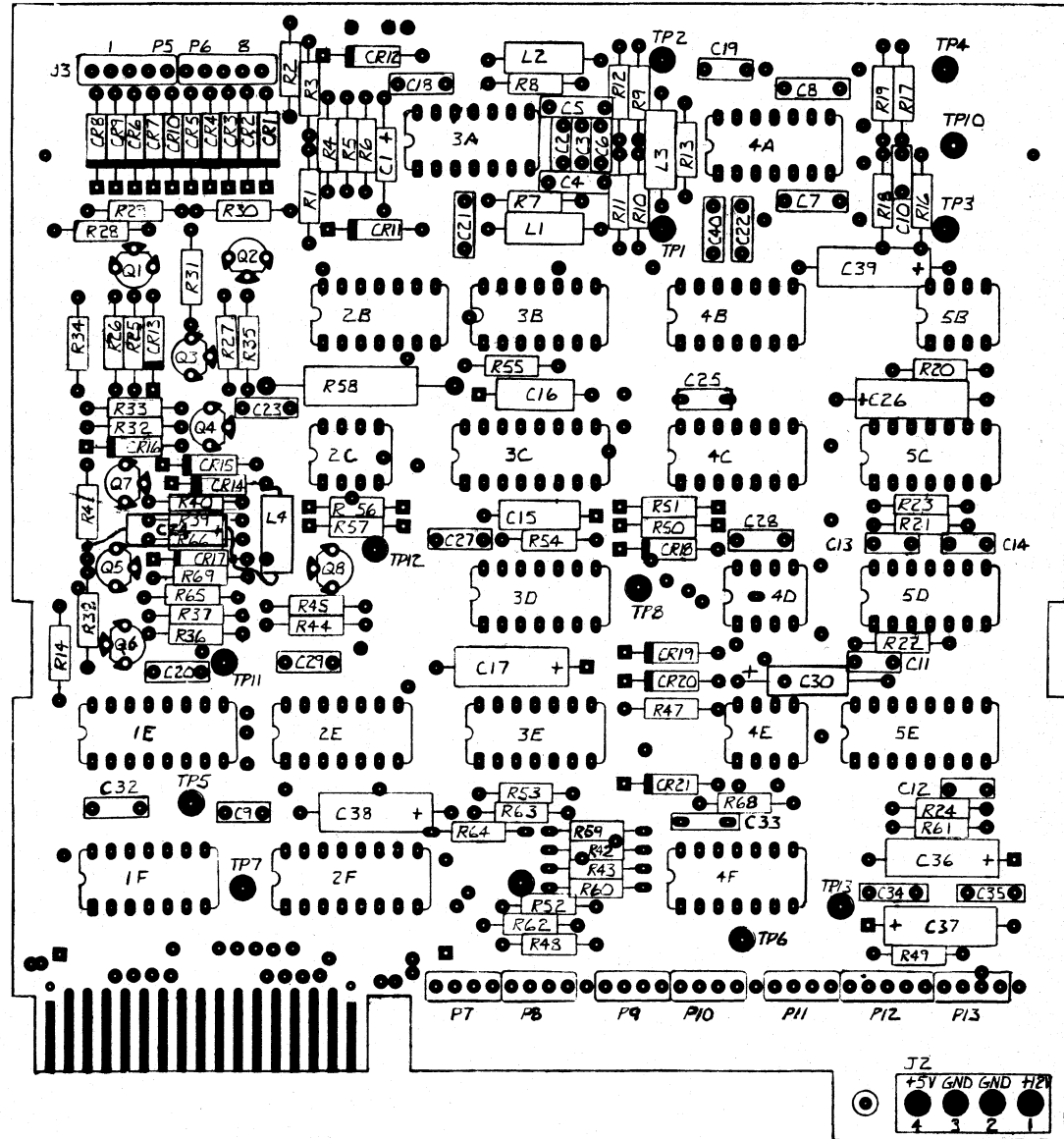

96/100 TPI

UNIPOLAR LOGIC PCBA ASSEMBLY DRAWING

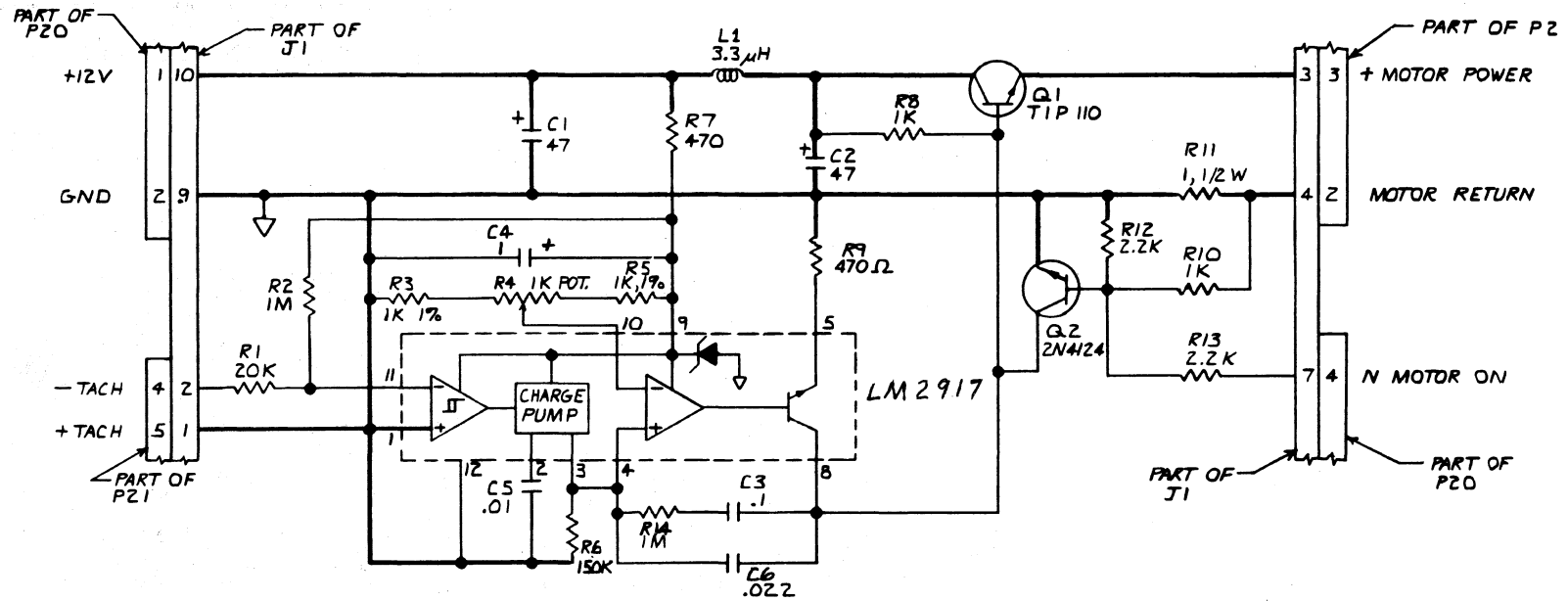

1-7

NOTES: UNLESS OTHERWISE SPECIFIED

1. RESISTORS ARE IN OHMS, ±5%, 1/4 W.
2. 1% RESISTORS ARE 1/8 W.
3. CAPACITORS ARE IN uf, ±20%, 35V.

SERVO PCBA SCHEMATIC

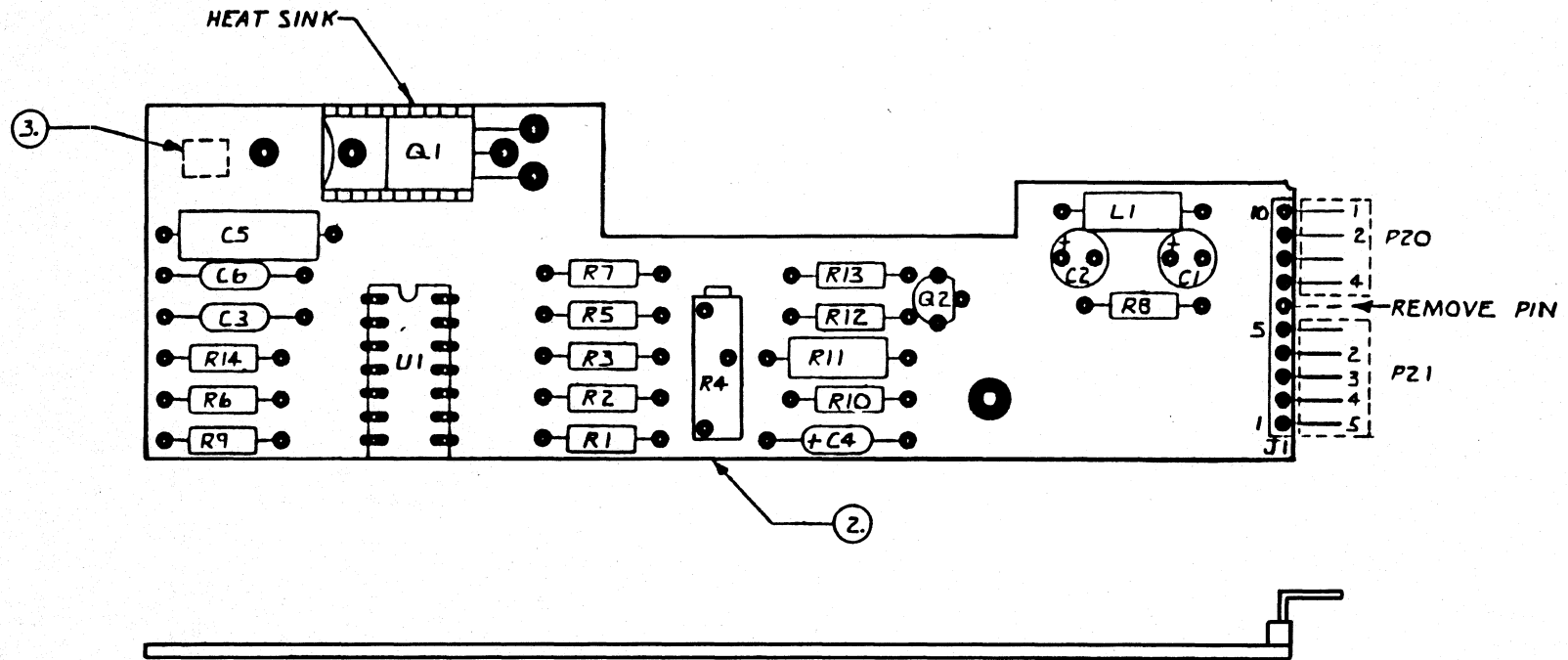

NOTES: UNLESS OTHERWISE SPECIFIED

1. ASSEMBLE PER STANDARD MANUFACTURING METHODS.
2. THIS ASSEMBLY SHALL BE MADE FROM PCB DETAIL 178901-001, REVISION A.

SERVO PCBA SCHEMATIC

APPENDIX II

TIMING REQUIREMENTS

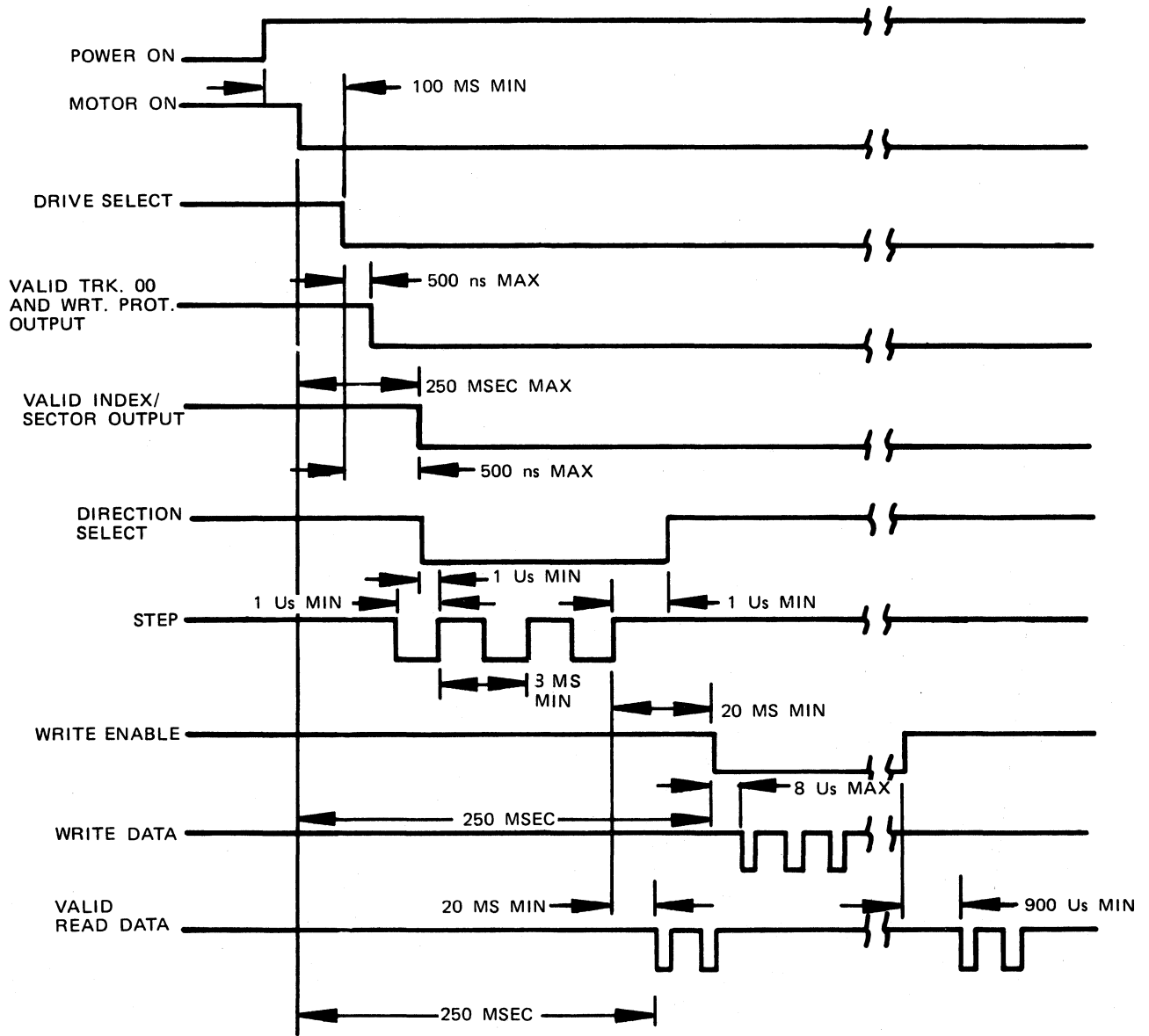

MODEL TM100 GENERAL CONTROL AND DATA TIMING REQUIREMENTS

PRODUCT SPECIFICATION
 MINI SINGLE AND DOUBLE-SIDED RECORDINGS
 FLEXIBLE DISK DRIVES

APPENDIX III

RECOMMENDED SPARE PARTS LIST

PARTS AND SUBASSEMBLIES

<u>Part Number</u>	<u>Description of Part</u>
171014-001	Drive Motor
171042-001	Track 00 Sensor Assembly
171005-001	Write Protect Switch Assembly
171045-001	Logic PCBA, Bipolar
177004-001	Logic PCBA, Unipolar
177533-001	Ready Line PCBA
171111-001	Servo PCBA
914000-001	Drive Belt
171041-001	Index Assembly II or III (Interchangeable)
171010-001	LED Assembly
172000-001	Cone Lever Assembly (one piece)
172001-001	Latch Plate Assembly
172230-001	Right-Hand Guide
172231-001	Left-Hand Guide
172027-002	Front Panel With Bushings
171046-001	Spindle Assembly
171203-001	Module Assembly Double-Sided Recording, Unipolar (96 TPI)
171203-002	Module Assembly Single-Sided Recording, Unipolar (96 TPI)
174203-001	Module Assembly Double-Sided Recording, Unipolar (100 TPI)
174203-002	Module Assembly Single-Sided Recording, Unipolar (100 TPI)
171209-001	Module Assembly Double-Sided Recording, Bipolar (96 TPI)
171209-002	Module Assembly Single-Sided Recording, Bipolar (96 TPI)
174005-001	Module Assembly Double-Sided Recording, Bipolar (100 TPI)
174005-002	Module Assembly Single-Sided Recording, Bipolar (100 TPI)
171103-001	Single-Sided Recording Upper Arm
172266-001	Track 00 Block
171002-005	Cone Lever Assembly

NOTE

All components are standard commercial parts purchased to original equipment manufacturer's specifications.

**OEM OPERATING AND SERVICE MANUAL, TM100-3, -3M, -4, AND -4M DISK DRIVES,
96/100 TPI, TANDON P/N 179024-001**

ALIGNMENT DISKETTE

Recommended: Dysan P/N 802020, Model Number 206-30

P/N 179024-001
Notice 1
July 29, 1981

OEM OPERATING AND SERVICE MANUAL
TM100-3, -3M, -4, AND -4M DISK DRIVES
96/100 TRACKS PER INCH

TO ALL HOLDERS OF P/N 179024-001:

1. Page 2-13, Sections 2.6 through 2.6.1.14, has been revised and supersedes the one in the manual.
2. Page 2-14, Sections 2.6.2 through 2.6.2.7, has been added to the manual.
3. Retain this notice and insert it before the table of contents.
4. Holders of P/N 179024-001 will verify that the page changes indicated herein have been entered. This notice will be retained as a check sheet. This issuance is a separate publication. Each notice is to be retained until the OEM operating and service manual is completely revised.

Preparing Group:
Product Support, Tandon Corporation

2.6.2 Track 00 Sensor Adjustment Procedure

- 2.6.2.1 Loosen the retaining screw on the base of the Track 00 bracket.
- 2.6.2.2 Retighten the retaining screw slightly to provide some friction on the bracket.
- 2.6.2.3 Rotate the Track 00 adjustment screw, located at the rear of the chassis, counterclockwise as far as it will go without forcing it.
- 2.6.2.4 Step the carriage back to Track 01 from the radial alignment track, taking care not to restore it back to Track 00.
- 2.6.2.5 Rotate the Track 00 adjustment screw clockwise, very slowly, until the signal at IC4B, Pin 9, is true (+5 volts) at Track 01 and false (0 volts) at Track 02.
- 2.6.2.6 Retighten the retaining screw.
- 2.6.2.7 Repeat Steps 2.6.1.5 through 2.6.1.14 to ensure that the correct setting has been attained.

2.6 TRACK 00 SENSOR CHECK AND ADJUSTMENT

The Track 00 sensor provides a signal that identifies Track 00 to the logic electronics. The logic electronics disable the step-in function when Track 00 is reached. In addition, a Track 00 signal is sent to the controller on Pin 26 of the interface.

2.6.1 Track 00 Sensor Check

- 2.6.1.1 Set up a dual-channel, wideband oscilloscope as follows:
- Channel A, Test Point 1; Channel B, Test Point 2
- Ground: Test Point 10
- Read Differentially: A plus B, B inverted
- Time Base: 20 msec Per Division
- External Trigger: Test Point 7, Positive Edge
- Vertical Display: 0.1 Volt Per Division
- 2.6.1.2 Apply power to the disk drive.
- 2.6.1.3 Insert a Cats Eye (CE) alignment diskette into the disk drive.
- 2.6.1.4 Close the front door.
- 2.6.1.5 Step the carriage to the radial alignment track.
- 2.6.1.6 Confirm the position by observing the CE pattern.
- 2.6.1.7 Set up the oscilloscope to monitor the TTL signal at IC4B, Pin 9, or at P11, Pin 2.
- 2.6.1.8 Step the carriage back to Track 01.
- 2.6.1.9 Ensure that the signal at Track 01 is logical true.
- 2.6.1.10 Step the carriage out to the radial alignment track.
- 2.6.1.11 Step the carriage back to Track 02.
- 2.6.1.12 Verify that the logic level at IC4B, Pin 9, is logical false.
- 2.6.1.13 If all of the above checks are satisfactory, no adjustment is required.
- 2.6.1.14 If one of the above checks is unsatisfactory, perform the Track 00 adjustment procedure.